



# ULTRA-FREEZE<sup>®</sup>

## CRYOGENIC FREEZER SPARE PARTS MANUAL

AND

PRICING GUIDE  
(In U.S. Dollars)

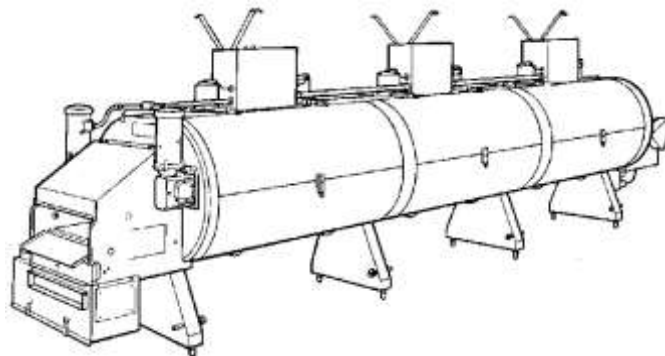

09/2019

# **CONTENTS**

<b>Section</b>	<b>Description</b>
1	Exit Vestibule – 3 Tier
2	Entry Vestibule – 3 Tier
3	Exit Vestibule – 1 Tier
4	Entry Vestibule – 1 Tier
5	Variable Speed Fans
6	Fixed Speed Fans
7	Module Related Parts
8	CO2 Manifold Injection
9	LN2 Manifold Injection
10	Door Latch
11	Lower Plunger and Hinge
12	Upper Plunger and Hinge
13	Control Cabinet
14	Limit Switch- Door Safety Switch- Fan Blades Stop When Doors Open
15	Door Gasket & Gasket Hardware
16	Installation Belt Support-Entry
17	Conveyor Brush Assembly

## **To Order**

Please call our Customer Service Department (815) 468-6115



For part number and price of any part not found in this manual please call (815) 468-6115







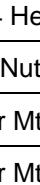
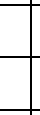
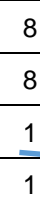
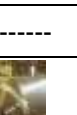

All credit cards accepted

# SECTION

# 1

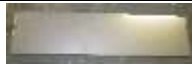
## ULTRA-FREEZE® EXIT VESTIBULE ASSEMBLY 30"- 3 Tier & 48" – 3 Tier

	Part Number	Description	Qty.	Picture of Part
	550682	Exit End Vestibule Assembly 30" - 3 Tier	1	-----
	550652	Exit End Vestibule Assembly 48" - 3 Tier	1	
<b>30" &amp; 48" 3 TIER EXIT END VESTIBULE ASSEMBLY PARTS SOLD SEPARATELY</b>				
74	12-550702 12-550718	Curtain 30" Curtain 48"	1 1	-----
73	550731 550732	Curtain Hanger 30" Curtain Hanger 48"	1 1	
72	551347 551348	Vestibule Trough Floor Plate 30" Vestibule Trough Floor Plate 48"	1 1	
70	110102	1/4-20 Hex Nut S.S.	2	-----
69	570115	Decal, Ultra-Freezer®	1	
68	570259	Decal, Caution	1	
67	120102	1/4 Dia. Flat Washer S.S.	2	-----
66	100512	5/16-24 x 5/8 Set Scr. S.S.	12	-----
65	100135	1/4-20 x 2 1/4 Hex Hd Scr. S.S.	4	-----
64	550981-11	Conveyor Wear Strip	2	
63	550650	Conveyor Support	2	
62	100101	3/8-16 x 1 1/2 Hex Screw S.S	8	-----
61	100518	3/8-16 x 3/4 Hex Hd S.S.	8	-----
60	110102	1/4-20 Hex Nut S.S.	8	-----
59	550326	Plate, Motor Mtg.	1	
58	550327	Plate, Motor Mtg.	1	
57	570053	Gear Reducer (Blue) 60:1 Left	1	
56	570377	Gear Reducer (Blue) 50:1 Right	1	
57	570053-1	Gear Reducer Stainless 60:1	1	
56	570377-1	Gear Reducer Stainless 50:1	1	
55	570004	Motor D.C. 1 HP (Blue)	2	
	920100-1	Motor A.C. 1 HP Stainless	2	

54	550369	1/4 Sq. x 2/34 S.S.	1	
53	550368	1/4 Sq. x 31/32 S.S.	7	
52	135113	Drive Pin 3/16 D. x 1 1/4 S.S.	4	-----
51	100519	5/16-18 x 1/2 Set Screw S.S.	10	-----
50	120103	Flat Washer S.S.	2	-----
49	110110	#10 -24 Hex Nut S.S.	8	-----
48	100119	#10-24 x 3/8 Hex Hd Scr S.S.	4	-----
47	100118	#10-24 x 1/2 Hex Hd Scr. S.S	14	-----
46	100123	5/8-11 x 1 1/2 Hex Hd Scr SS	1	-----
45	120306	1/2 Dia Lock Washer S.S.	1	-----
44	120108	1/2 Dia Flat Washer S.S.	1	-----
43	110114	1/2-13 Hex. Nut S.S.	1	-----
42	100122	1/2-13 x 2 3/4 Hex Hd Scr SS	1	-----
41	570316	Connecting Link 1/2-40	1	
40	120106	5/16 Dia Washer S.S.	6	-----
39	110106	5/16-18 Hex Nut S.S.	4	-----
38	550407	5/16-18 x 3 1/2 Stud S.S.	2	
37	100114	5/16-18 x 2 1/4 Hex Scr. S.S.	2	-----
36	100131	5/16-18 x 5/8 Hex Hd Scr SS	4	-----
35	100128	1/4-20 x 1 1/4 Hex Hd Scr SS	10	-----
34	550597	Angle, Discharge Chute	1LH 1RH	
33	100110	1/4-20 x 1/2 Hex Hd Scr SS	6	-----
32	120102	1/4 Dia Flat Washer S.S.	9	-----
31	551329 551035	Chute Product Assembly 30" Chute Product Assembly 48"	1 1	
30	120308	1/4 Lockwasher S.S.	2	-----
29	570315	Coupling 1" Bore - 1 1/8"	1	
28	550328	Shaft Idler	2	
27	550330	Idler - 2" Dia	2	
26	550336	Spacer - Idler	2	

24	550335	Exhaust Cover	1	
23	550661	Breaker Bar Assembly 30"	1	
	550601	Breaker Bar Assembly 48"	1	
22	570314	Chain	67 3/4" or 5.65'	
21	550644	Cover Hinged	1	
19	550579	Chain Guard	1	
18	550669	Support, Chain - L.H.	1	
17	550668	Support, Chan - R.H.	1	
16	550331	Arm, Chain Tightener	1	
15	570312	Sprocket Idler 17 TRC	1	
14	570310	Sprocket - 1" Bore 20 TRC	2	
13	570311	Sprocket – 1 1/8" Bore 20 TRC	1	
12	550573	Sprocket - Top Tier 10T Spec	2	
11	570049	Conveyor Sprocket 12T (Ash)	4	
10	550315	Bearing - 1" Dia. Shaft	5	
9	550607	Bearing Retainer Clip	5	
8	550038	Conveyor Belt Support	6	
7	550624	Belt Support Sprocket	3	
6	550314	Shaft, Drive Direct	1	
	551047	Shaft, Drive Direct	1	
5	550313	Shaft, Drive 30"	2	
	550576	Shaft, Drive 48"	2	
4	551376	Proportioning Exhaust Baffle 30"	1	
	551375	Proportioning Exhaust Baffle 48"	1	
3	551359	Exit End Exhaust By-Pass 30"	1	
	551356	Exit End Exhaust By-Pass 48"	1	
2	550888	Exhaust Discharge Assembly 30"	1	
	-----	Exhaust Discharge Assembly 48"	1	
1	550979	Exit End Enclosure 30"	1	-----
	550653	Exit End Enclosure 48"	1	

Effective Date: 09/2019

**NOTES:**

1. FILL GEAR BOX TO THE LEVEL OF THE VENT OIL FILLER PLUG.
2. INSTALL VENTED FLOAT THIS LIMITATION WITH VENT HOLE AND ARROW POINTED UP (SUPPLIED WITH GEAR REDUCER).
3. INSTALL SQUARE HEAD PLUG AT THIS LOCATION (SUPPLIED WITH GEAR REDUCER).
4. ALL OTHER OPEN HOLES IN GEAR REDUCER TO BE CLOSED USING HEX 20G. PLUGS (SUPPLIED WITH GEAR REDUCER).

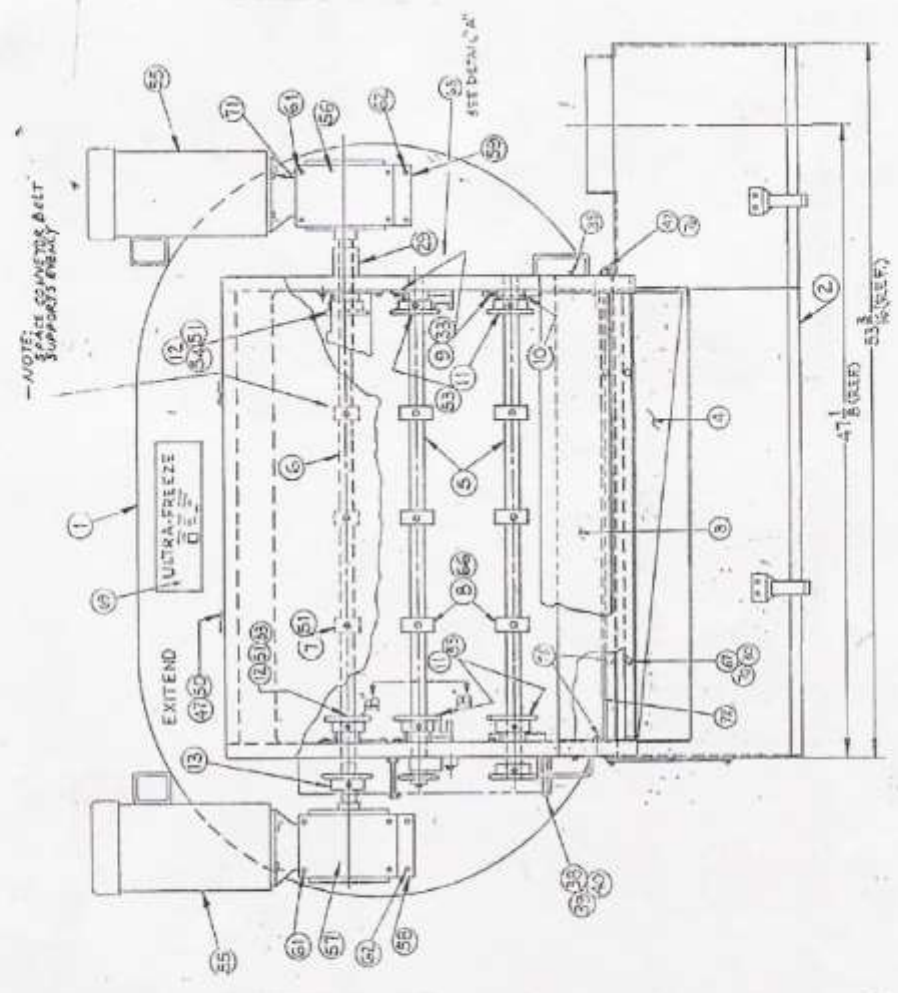
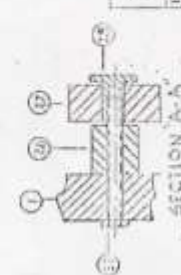
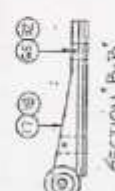
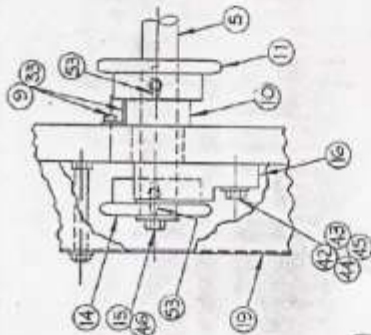

NOTE: GUNNETER & GET SUPPLIES ENERGY

**VARIABLE TABLE**

51	520-570053	GEAR REDUCER RM. 52-1
		F 331-6076
56	450-570377	GEAR REDUCER L.N. 10-1
		F 334-60-J
55	520-570005	MOTOR DC 1/4 HP
		520-570026
		520-570376
		MOTOR DC 1/2 HP

**SHIMS TABLE**

ITEM	QTY	DESCRIPTION
76	1	SHIMS
77	1	SHIMS
78	1	SHIMS
79	1	SHIMS
80	1	SHIMS
81	1	SHIMS
82	1	SHIMS
83	1	SHIMS
84	1	SHIMS
85	1	SHIMS
86	1	SHIMS
87	1	SHIMS
88	1	SHIMS
89	1	SHIMS
90	1	SHIMS
91	1	SHIMS
92	1	SHIMS
93	1	SHIMS
94	1	SHIMS
95	1	SHIMS
96	1	SHIMS
97	1	SHIMS
98	1	SHIMS
99	1	SHIMS
100	1	SHIMS

ITEM	QTY	DESCRIPTION
1	1	SHIMS
2	1	SHIMS
3	1	SHIMS
4	1	SHIMS
5	1	SHIMS
6	1	SHIMS
7	1	SHIMS
8	1	SHIMS
9	1	SHIMS
10	1	SHIMS
11	1	SHIMS
12	1	SHIMS
13	1	SHIMS
14	1	SHIMS
15	1	SHIMS
16	1	SHIMS
17	1	SHIMS
18	1	SHIMS
19	1	SHIMS
20	1	SHIMS
21	1	SHIMS
22	1	SHIMS
23	1	SHIMS
24	1	SHIMS
25	1	SHIMS
26	1	SHIMS
27	1	SHIMS
28	1	SHIMS
29	1	SHIMS
30	1	SHIMS
31	1	SHIMS
32	1	SHIMS
33	1	SHIMS
34	1	SHIMS
35	1	SHIMS
36	1	SHIMS
37	1	SHIMS
38	1	SHIMS
39	1	SHIMS
40	1	SHIMS
41	1	SHIMS
42	1	SHIMS
43	1	SHIMS
44	1	SHIMS
45	1	SHIMS
46	1	SHIMS
47	1	SHIMS
48	1	SHIMS
49	1	SHIMS
50	1	SHIMS
51	1	SHIMS
52	1	SHIMS
53	1	SHIMS
54	1	SHIMS
55	1	SHIMS
56	1	SHIMS
57	1	SHIMS
58	1	SHIMS
59	1	SHIMS
60	1	SHIMS
61	1	SHIMS
62	1	SHIMS
63	1	SHIMS
64	1	SHIMS
65	1	SHIMS
66	1	SHIMS
67	1	SHIMS
68	1	SHIMS
69	1	SHIMS
70	1	SHIMS
71	1	SHIMS
72	1	SHIMS
73	1	SHIMS
74	1	SHIMS
75	1	SHIMS
76	1	SHIMS
77	1	SHIMS
78	1	SHIMS
79	1	SHIMS
80	1	SHIMS
81	1	SHIMS
82	1	SHIMS
83	1	SHIMS
84	1	SHIMS
85	1	SHIMS
86	1	SHIMS
87	1	SHIMS
88	1	SHIMS
89	1	SHIMS
90	1	SHIMS
91	1	SHIMS
92	1	SHIMS
93	1	SHIMS
94	1	SHIMS
95	1	SHIMS
96	1	SHIMS
97	1	SHIMS
98	1	SHIMS
99	1	SHIMS
100	1	SHIMS

# **SECTION**

# **2**





## ULTRA-FREEZE®

### ENTRY VESTIBULE ASSEMBLY 30"- 3 Tier & 48" - 3 Tier

	Part Number	Description	Qty.	Picture of Part
	550681	Entry End Vestibule Assembly 30" – 3 Tier	1	-----
	550655	Entry End Vestibule Assembly 48" - 3 Tier	1	
<b>30" &amp; 48" 3 TIER ENTRY END VESTIBULE ASSEMBLY PARTS SOLD SEPARATELY</b>				
58	120308	¼" Lockwasher S.S.	2	-----
57	120102	¼" Flat Washer S.S.	2	-----
56	110102	¼"-20 NC Hex Nut S.S.	2	-----
55	551297	Vapor Guide Baffle LH & RH	2	
53	550701	Hood, Entry End 30"	1	
	550716	Hood, Entry End 48"	1	
52	12-550703	Entry Curtain 30"	1	-----
	12-550719	Entry Curtain 48"	1	
51	550704	Curtain, Hanger 30"	1	
	550720	Curtain, Hanger 48"	1	
50	551376	Proportioning Exhaust Baffle	1	
49	551365	Exit End Exhaust 30"	1	
	551374	Exit End Exhaust 48"	1	
45	551475	Model/ Serial/ Data Plate	1	
44	570259	Decal, Caution	1	
43	570115	Decal, Ultra-Freeze®	1	
42	100104	1/4-20 x 3/4	2	-----
40	100512	Set Screw Hex S.S.	6	-----
39	550851	Washer, Entry Take-Up	2	
38	120101	3/8 Dia. Flat Washer S.S.	2	-----
37	110112	3/8-16 Hex. Nut S.S.	4	-----
36	110110	#10-24, Hex Nut S.S.	13	-----
35	100119	#10-24 x 3/8 Hex Screw S.S.	4	-----

34	100128	1/4-20 x 1 1/4" Hex Screw S.S.	6	-----
33	100118	#10-24 x 1/2" Hex Screw S.S.	27	-----
32	100110	1/4-20 x 1/2" Hex Screw S.S.	10	-----
31	100519	5/16-18 x 1/2" Set Screw S.S.	9	-----
30	100802	3/8-16 x 1 1/4" Flat Hd Scr. S.S	8	-----
27	550430	Guide, Vestibule (Take-Up)	4	
26	100130	5/16-18 x 2 1/2 Hex Hd S.S.	2	-----
25	550012	3/8-16 x 6 3/8 Threaded Rod	2	
23	550336	Spacer Idler	2	
22	550330	Idler - 2" Dia	2	
21	550328	Shaft Idler	2	
20	550363	Spacer Bearing	2	
19	550508 550648	Shaft - 3/4" Dia. 30" Shaft - 3/4" Dia. 48"	1 1	
18	550525	Support, Conveyor Belt	3	
17	551185	Sprocket, Belt Idler	2	
16	550507	Bearing, 3/4" Dia. Shaft	2	
15	550651	Take-Up Clevis	2	
14	550607	Bearing Retainer Clip	2	
13	550315	Bearing 1" Dia Shaft	2	
12	550038	Conveyor Belt Support	3	
11	550313 550576	Shaft - 1" Dia. 30" Shaft - 1" Dia. 48"	1 1	
10	570049	Sprocket 12 Tooth	2	
9	550942	Wear Strip - 67 7/8" length	2	
8	550335	Exhaust Cover	1	

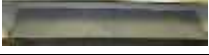
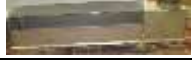
7	551186	Spacer, Bearing	2	
6	100104	¼"-20 Hex Hd Screw S.S.	4	-----
5	550639	Drip Shield - Entry 30"	1	
	550596	Drip Shield - Entry 48"	1	
4	550649	Entry End Conveyor Support	2	
3	551347	Vest. Trough Floor Plate 30"	1	
	551348	Vest. Trough Floor Plate 48"	1	
2	550889	Exhaust Discharge Assy. 30"	1	
	550882	Exhaust Discharge Assy. 48"	1	
1	550979	Entry End Enclosure 30"	1	-----
	550656	Entry End Enclosure 48"	1	

Effective Date: 09/2019

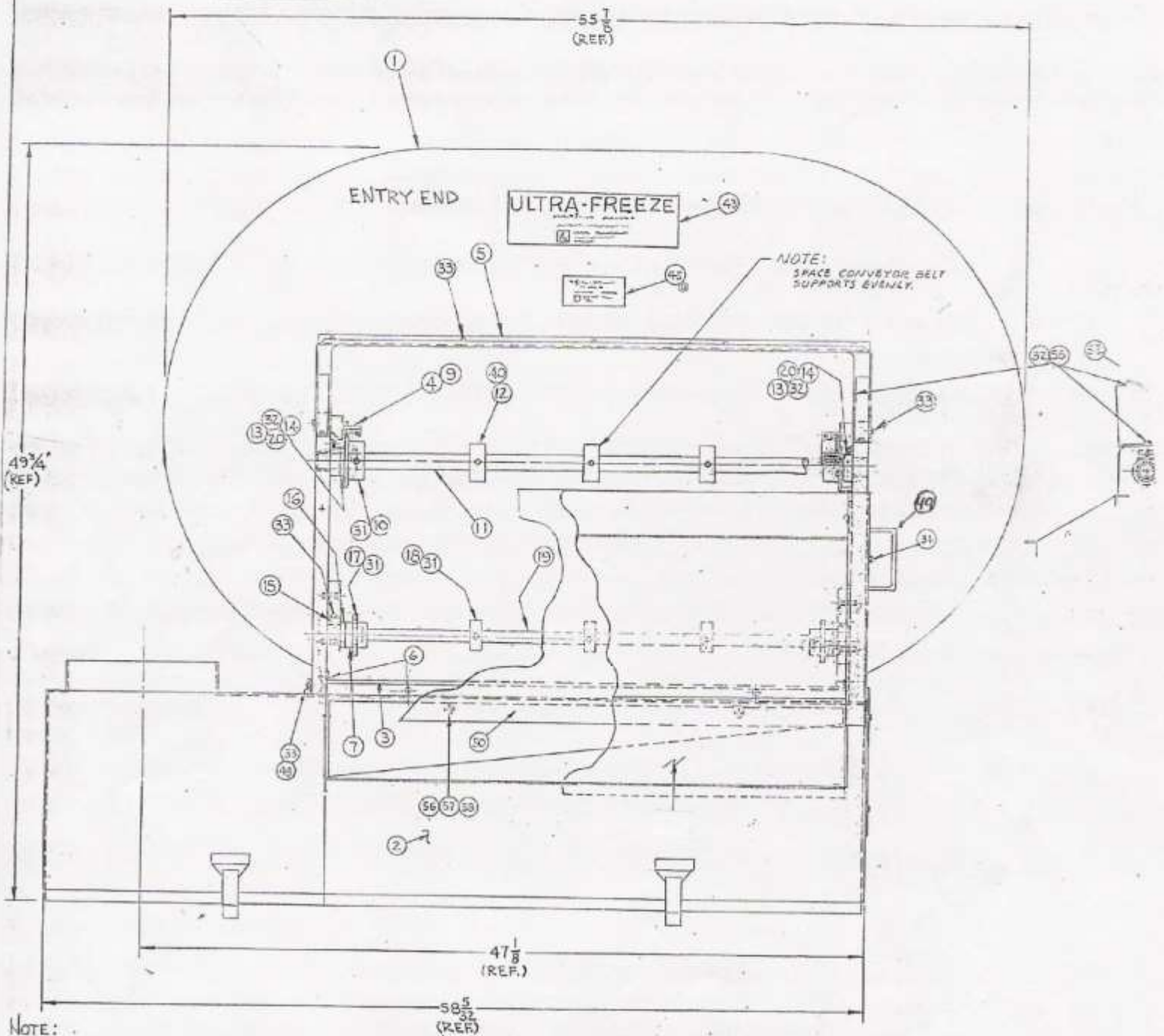
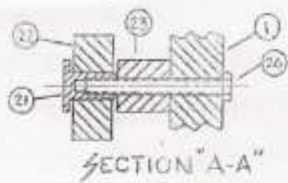

NOTE:  
 ASSEMBLER-WHEN REPLACING CONVEYOR BRUSH ASSEMBLY  
 REMOVE ITEMS #10, #11 AND #20.  
 REPLACE WITH A30-570049, A30-550313 AND PARTS  
 FROM BRUSH ASSEMBLY D30-550722-1



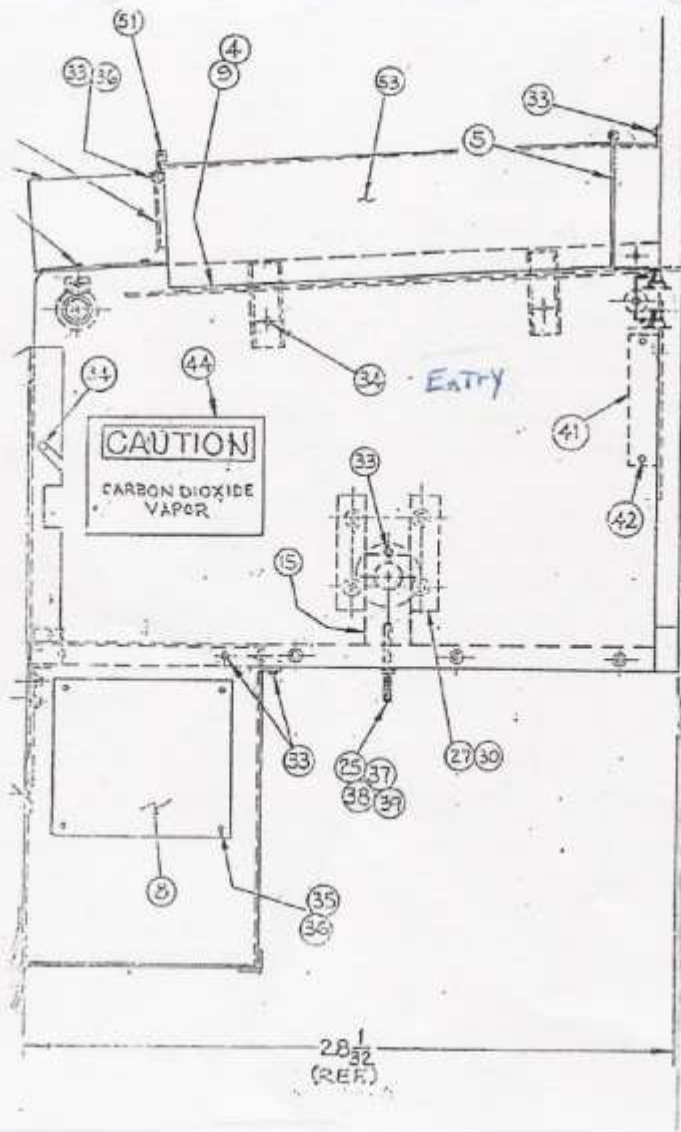



ITEM	PART NO.	DESCRIPTION
43	A30-550462	MOUNTING SHIM-THICK
	A30-550461	MOUNTING SHIM-MEDIUM
	A30-550460	MOUNTING SHIM-THIN
SHIM TABLE		





# SECTION

# 3

## ULTRA-FREEZE® EXIT VESTIBULE ASSEMBLY 30" - 1 Tier & 48" - 1 Tier

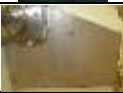
	Part Number	Description	Qty.	Picture of Part
	550866	Exit End Vestibule Assembly 30" - 1 Tier	1	-----
	550785	Exit End Vestibule Assembly 48" - 1 Tier	1	
<b>30" &amp; 48" 1 TIER EXIT END VESTIBULE ASSEMBLY PARTS SOLD SEPARATELY</b>				
65	See Table	Shims	-----	-----
64	100104	1/4-20 Hex Hd. Cap Scr. S.S.	4	-----
63	120102	1/4 Flat Washer S.S.	2	-----
62	120308	1/4 Lock washer S.S.	2	-----
61	110102	1/4-20 NC Nut S.S.	2	-----
60	570259	Decal, Caution	1	
59	100140	5/16-18 Hex Hd. Cap Scr.	1	-----
58	570050	Wear strip 18" Lg.	2	
57	550607	Bearing Retainer Clip	2	
56	120108	1/2 Flat Washer	1	-----
55	120106	5/16 Flat Washer	2	-----
53	120103	#10 Flat Washer	6	-----
52	120306	1/2 Split Lock washer	1	-----
51	100131	5/16-18 Hex Hd. Machine Scr.	10	-----
50	110102	1/4-20 Hex. Nut - S.S.	8	-----
49	110114	1/2-13 Hex Nut	1	-----
48	110106	5/16-18 Hex Nut	4	-----
47	110110	#10-24 Hex Nut	17	-----
46	100512	5/16-24 Hex Soc. Set Scr.	4	-----
45	570115	Decal, Ultra-Freeze®	1	
44	550407	5/16-16 Stud. Cont. Thread	2	
43	551347 551348	Vestibule Trough Floor Plate 30" Vestibule Trough Floor Plate 48"	1 1	
42	100518	3/8-16 Hex Soc. Scr.	4	-----

41	100123	5/8-11 Hex Hd. Mach. Scr.	1	-----
40	100122	1/2-13 Hex Hd. Mach. Scr.	1	-----
39	100128	1/4-20 Hex. Hd. Cap Scr. S.S.	4	-----
38	100114	5/16-18 Hex Hd. Mach. Scr.	2	-----
37	100110	1/4-20 Hex Hd. Mach. Scr.	12	-----
36	100118	10-24 Hex Hd. Mach. Scr.	19	-----
35	100119	10-24 Hex Hd. Mach. Scr.	4	-----
34	100117	3/8-16 Hex Hd. Mach. Scr.	4	-----
33	550368	Key	1	
32	550704 550720	Curtain Hanger 30" Curtain Hanger 48"	1 1	
31	570004	Drive Motor, D.C. 1HP (Painted Blue)	1	
30	12-550702 12-550718	Curtain 30" Curtain 48"	1 1	-----
29	570053	Gear Reducer 60:1 (Painted Blue)	1	
28	550327	Plate, Motor Mounting	1	
27	120101	3/8 Flat Washer	4	-----
26	100138	3/8-16 Hex. Hd. Mach. Scr.	4	-----
25	551329 551035	Chute Product Discharge 30" Chute Product Discharge 48"	1 1	
24	551011	Conveyor Support Assy.	1	-----
23	550801	3" Dia. Idler Product Chain	1	
22	550579	Chain Guard	1	
21	570314	Chain		
20	570316	Connecting Link 1/2-40	1	
19	570312	Sprocket Idler 17 Tooth	1	
18	570311	Sprocket 1 1/8" Bore 20 Tooth	1	



17	570310	Sprocket 1" Bore, 20 Tooth	1	
16	550330	Idler 2" Dia.	2	
15	550328	Shaft Idler	3	
14	550336	Spacer, Idler	2	
13	570049	Conveyor Sprocket 12 T (Ash)	2	
12	550038	Conveyor Belt Support	2	
11	550315	Bearing, 1" Dia. Shaft	2	
10	550313 550576	Shaft, Drive 30" Shaft, Drive 48"	1 1	
9	550331	Arm, Chain Tightener	1	
8	550597L 550597R	Angle, Discharge Chute Angle, Discharge Chute	1 LH 1 RH	
7	550860 550778	Exit Cover Hinged Assy. 30" Exit Cover Hinged Assy. 48"	1 1	
6	100128	1/4-20 Hex Hd. Cap Scr. S.S.	2	-----
5	550335	Exhaust Duct Cover	1	
4	551376	Proportioning Exhaust Baffle	1	
3	551356	Exit End Exhaust By-Pass Assy.	1	
2	550889 550882	Exhaust Discharge Assy. 30" Exhaust Discharge Assy. 48"	1 1	
1	550869 550787	Exit End Enclosure 30" Exit End Enclosure 48"	1 1	-----

Effective Date: 09/2019

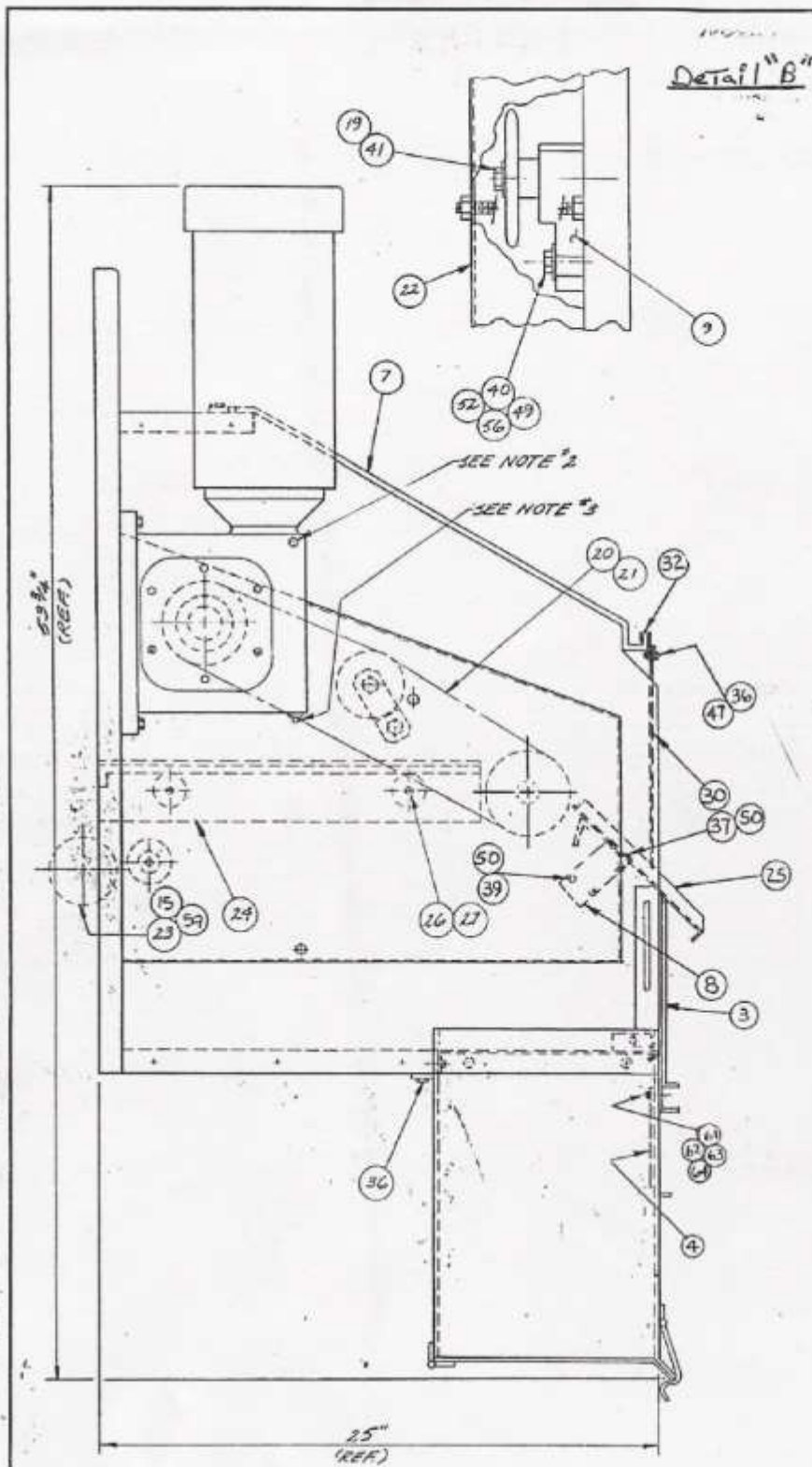

Detail "B"

53 3/4" (REF)

SEE NOTE 2

SEE NOTE 3

25" (REF)

(REF.)

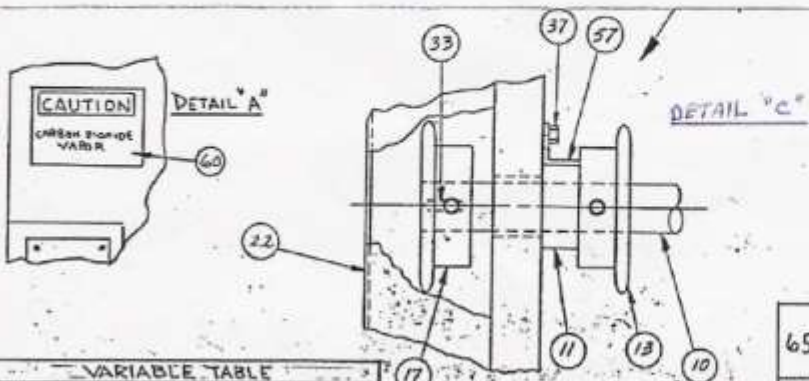

Detail "A"

Detail "C"

VARIABLE TABLE

31	A30-570004	DRIVE MOTOR 1 HP
	A30-570005	DRIVE MOTOR 3/4 HP

65	A30-550462	MOUNTING SHIM - THICK
	A30-550461	MOUNTING SHIM - MEDIUM
	A30-550460	MOUNTING SHIM - THIN
ITEM	PART NO	DESCRIPTION
SHIM TABLE		

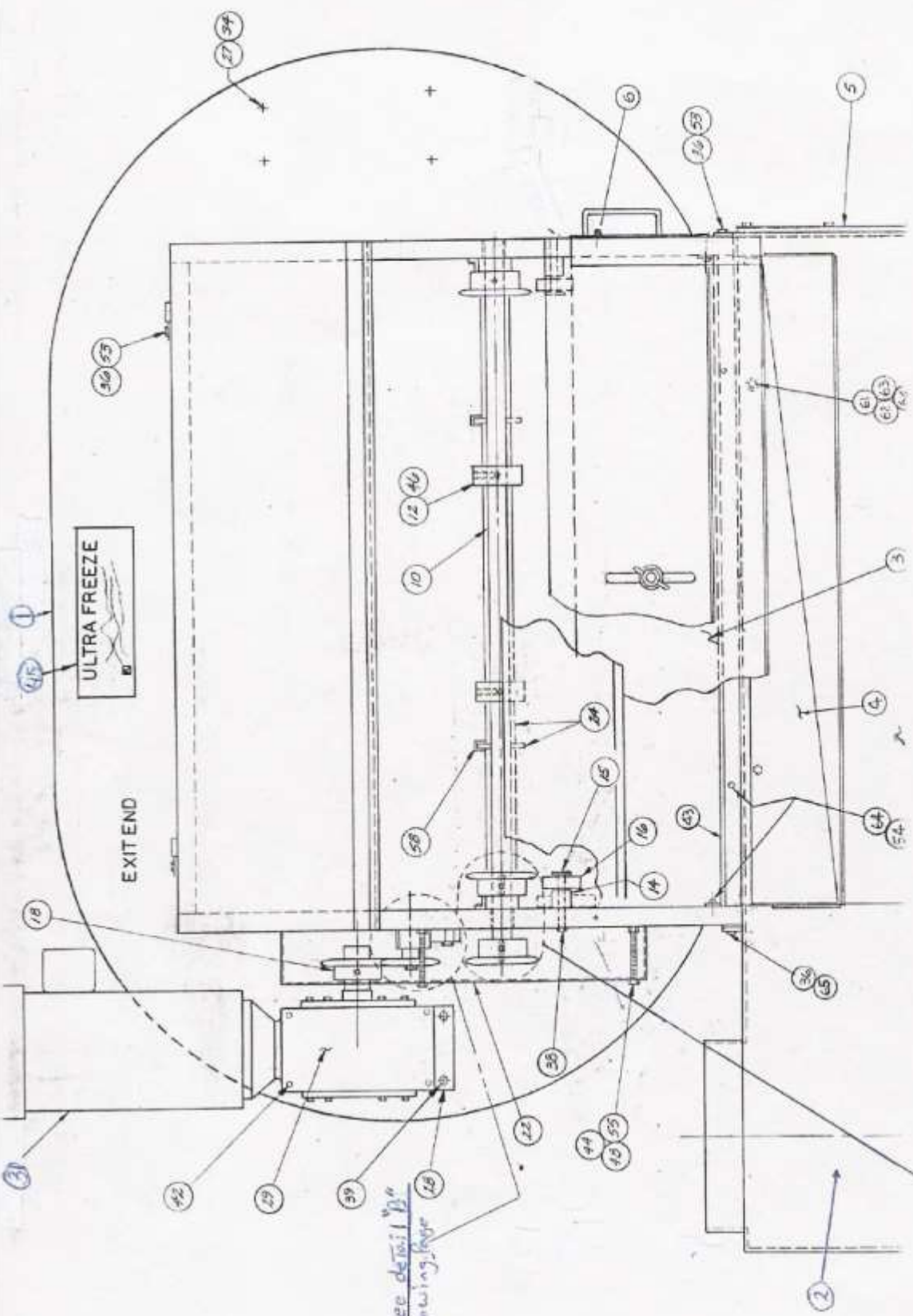

SEE DETAIL "C"  
FOLLOWING PAGE

See detail 1/2"  
Following page

ULTRA FREEZE

EXIT END

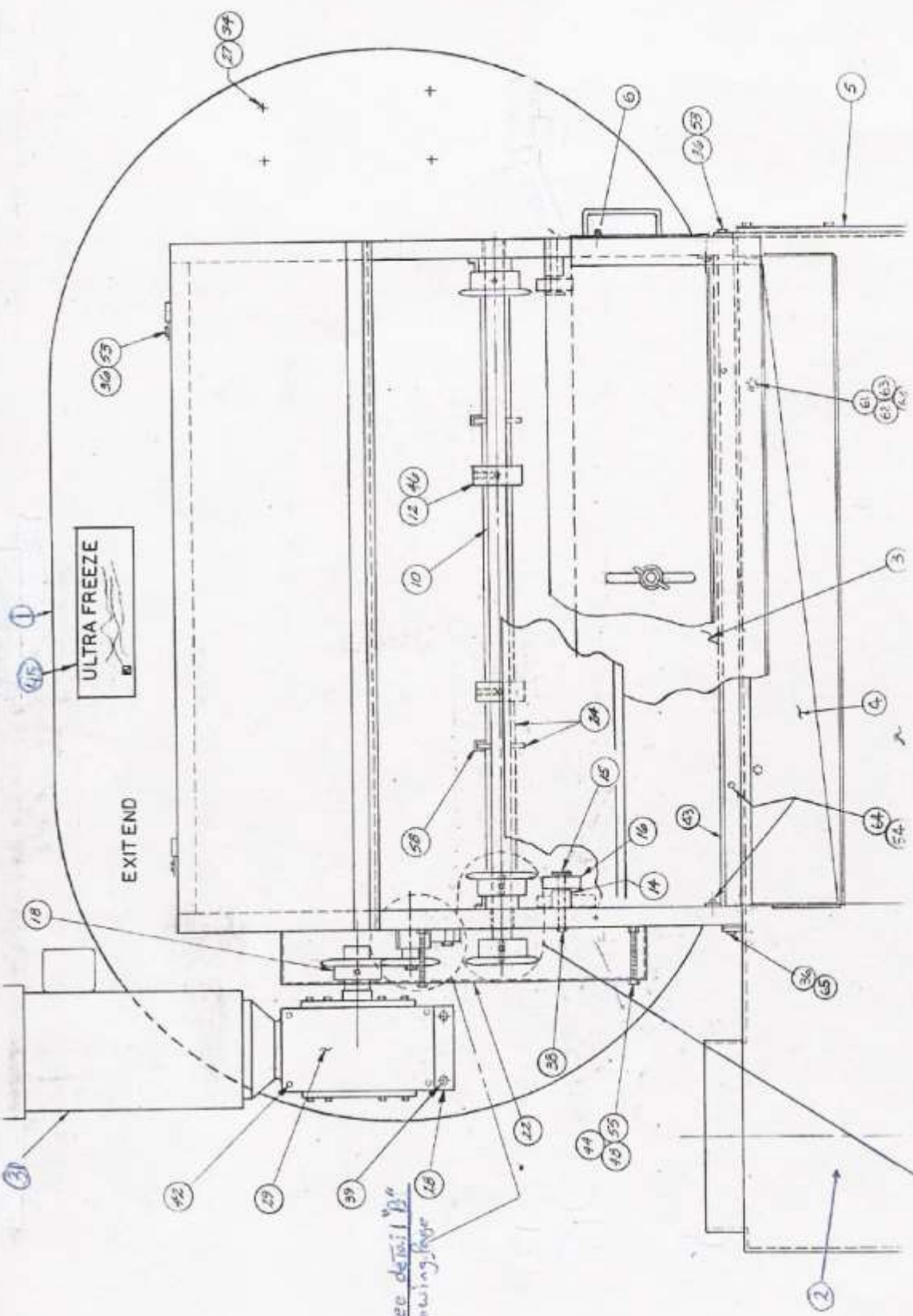

# SECTION

# 4

## ULTRA-FREEZE® ENTRY VESTIBULE ASSEMBLY 30"- 1 Tier & 48" – 1 Tier

	Part Number	Description	Qty.	Picture of Part
	550786	Entry End Vestibule Assembly 30" – 1 Tier	1	-----
	550786	Entry End Vestibule Assembly 48" - 1 Tier	1	
<b>30" &amp; 48" 1 TIER ENTRY END VESTIBULE ASSEMBLY PARTS SOLD SEPARATELY</b>				
49	See Table	Shim	1	-----
48	110102	1/4-20 Hex Nuts S.S.	3	-----
47	120102	1/4 Dia. Flat Washer S.S.	3	-----
46	120308	1/4 Lock washer S.S.	3	-----
45	551475	Model/ Serial No./ Data	1	
44	570115	Decal, Ultra-Freeze®	1	
43	570259	Decal, Caution	1	
42	100104	1/4-20 Hex Hd. Cap Scr. S.S.	8	-----
41	551297	Vapor Guide Baffle 1R.H. 1L.H.	2	
40	550720	Vapor Control Hanger	1	
39	550774 550701	Hood, Entry End 48" Hood, Entry End 30"	1 1	
38	120103	#10 Flat Washer	4	-----
37	100319	5/16-18 Set Scr. Cup Point	14	-----
36	570050	Wear strip, per foot	1	
35	120101	3/8 Flat washer	6	-----
34	100101	3/8-16 Hex Hd. Mach. Scr	4	-----
33	110112	3/8-16 Hex Nut	4	-----
32	550851	Washer - Entry Take Up	2	
31	551375	Proportioning Exhaust Baffle	1	
29	100119	#10-24 Hex Hd. Mach. Scr	4	-----
28	110110	#10-24 Hex Nut	17	-----
27	550719 550703	Vapor Control Curtain 48" Vapor Control Curtain 30"	1 1	-----

26	100802	3/8-16 UNC Flat Hd. Socket Scr	8	-----
25	100110	1/4-20 Hex Hd Mach Scr.	6	-----
24	100118	#10-24 Hex Hd. Mach Scr	34	-----
23	100512	5/16-24 Set Scr Hex Hd Cup Pt	6	-----
22	100128	1/4-20 Hex Hd Cap Scr S.S.	2	-----
21	551014	Conveyor Support Assy. 48"	1	-----
20	550525	Support Conveyor Belt	3	
19	550648	Take Up Shaft 3/4" dia 48"	1	
	550508	Take Up Shaft 3/4" dia 30"	1	
18	550507	Bearing 3/4" Dia Shaft	2	
17	551185	Sprocket Belt Idler 10T 3/4" Bore	2	
16	550012	3/8-16 Threaded Rod	2	
15	550651	Conveyor Take Up	2	
14	550607	Bearing Retainer Clip	2	
13	570049	Sprocket Entry/Exit 12T 1" Bore	2/4/6	-----
12	550038	Conveyor Belt Support	3	
11	550363	Spacer Bearing	2	
10	550315	Bearing 1" Dia. Shaft	2	
9	550574	Shaft 1" Dia. 48"	1	
	550341	Shaft 1" Dia. 30"	1	
8	550773	Drip Shield 48"	1	
	550863	Drip Shield 30"	1	
7	550430	Guide, Vestibule (Take-Up)	4	
6	551348	Vestibule Trough Floor Plate 48"	1	
	551347	Vestibule Trough Floor Plate 30"	1	
5	550335	Exhaust Duct Cover	1	
4	551186	Spacer, Bearing	2	
3	551371	Entry End Exhaust By-Pass 30"	1	
		Entry End Exhaust By-Pass 48"	1	
2	550881	Exhaust Discharge Assy. 48"	1	
	550888	Exhaust Discharge Assy. 30"	1	
1	550788	Entry Enclosure 48"	1	-----
	550870	Entry Enclosure 30"	1	

Effective Date 09/2019

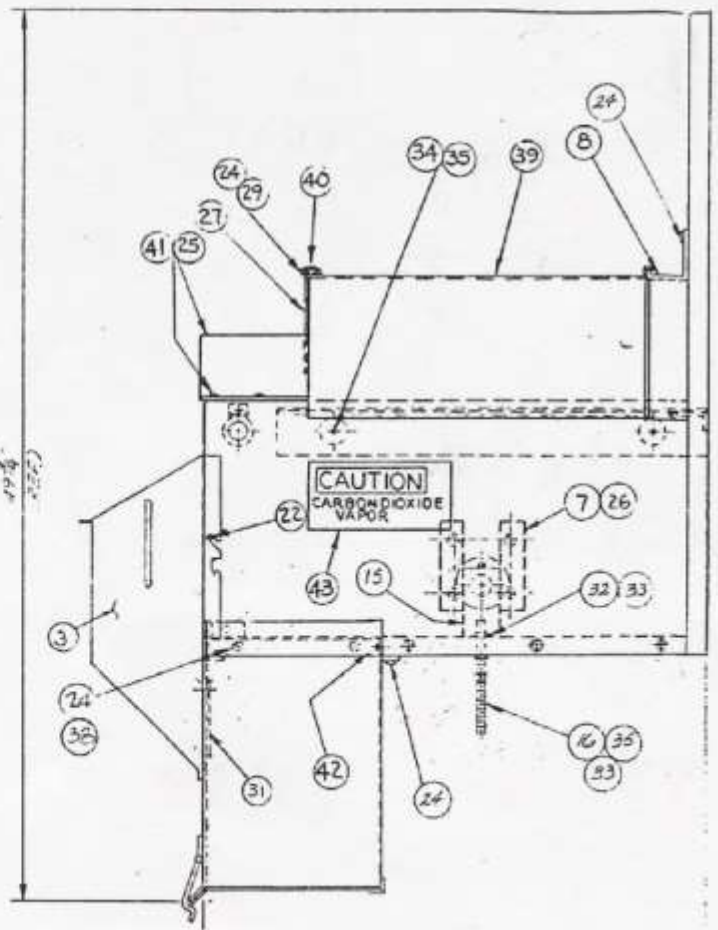
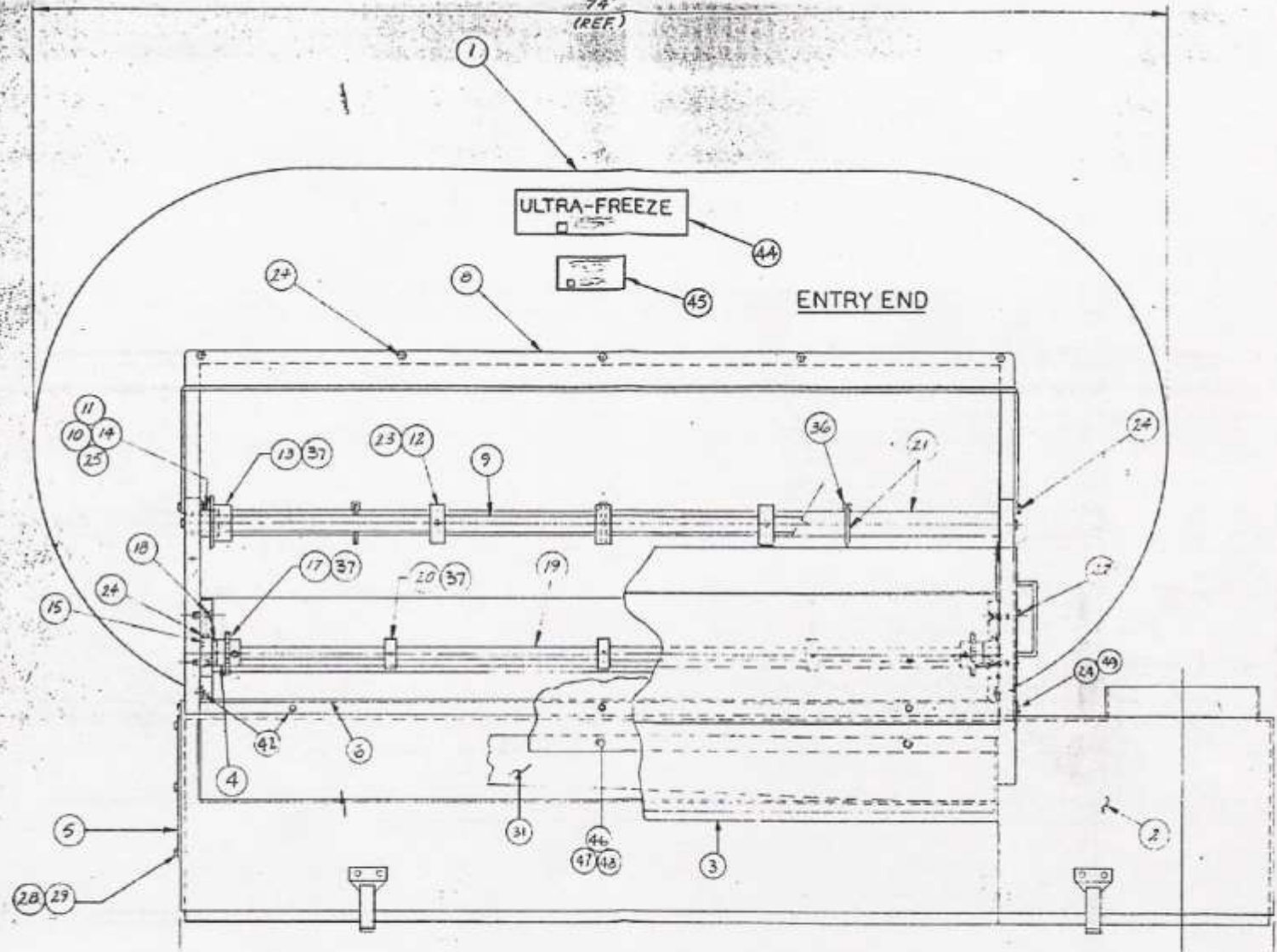

ITEM	PART NO.	DESCRIPTION
	A30-550462	MOUNTING SHIM-THICK
49	A30-550461	MOUNTING SHIM-MEDIUM
	A30-550460	MOUNTING SHIM-THIN
		SHIM TABLE

# SECTION

# 5



## ULTRA-FREEZE® VARIABLE SPEED FAN ASSEMBLY

	Part Number	Description	Qty.	Picture of Part
	550567	Variable Speed Fan Assembly	1	-----
<b>VARIABLE SPEED FAN ASSEMBLY PARTS SOLD SEPARATELY</b>				
16	160501	3/16 Sq. x 3/4 Key	1	
15	570263	Coupling	1	
14	100109	Screw 3/8-16 x 1/14 Hex Hd	4	-----
13	570354	Bearing	1	
12	100107	Screw, 5/16-18 x 3/4 Hex Hd	1	-----
11	160502	Key, 3/16 Sq. x 7/8	1	
10	550029	Thrust Washer	1	
9	570207	1179 Low Pitch Propeller	1	
8	570303	1171 High Pitch Propeller	1	
7	550561	Sleeve	1	
6	570356	Clamping Collar	1	
5	550565	Bearing Housing	1	
4	551385	Fan Shaft	1	
3	570357	Gasket	1	
2	100117	Screw 3/8-16 x 3/4 Hex Hd	4	-----
1	570009	1/2 HP Elec. Motor (Painted Blue)	1	

Effective Date: 09/2019

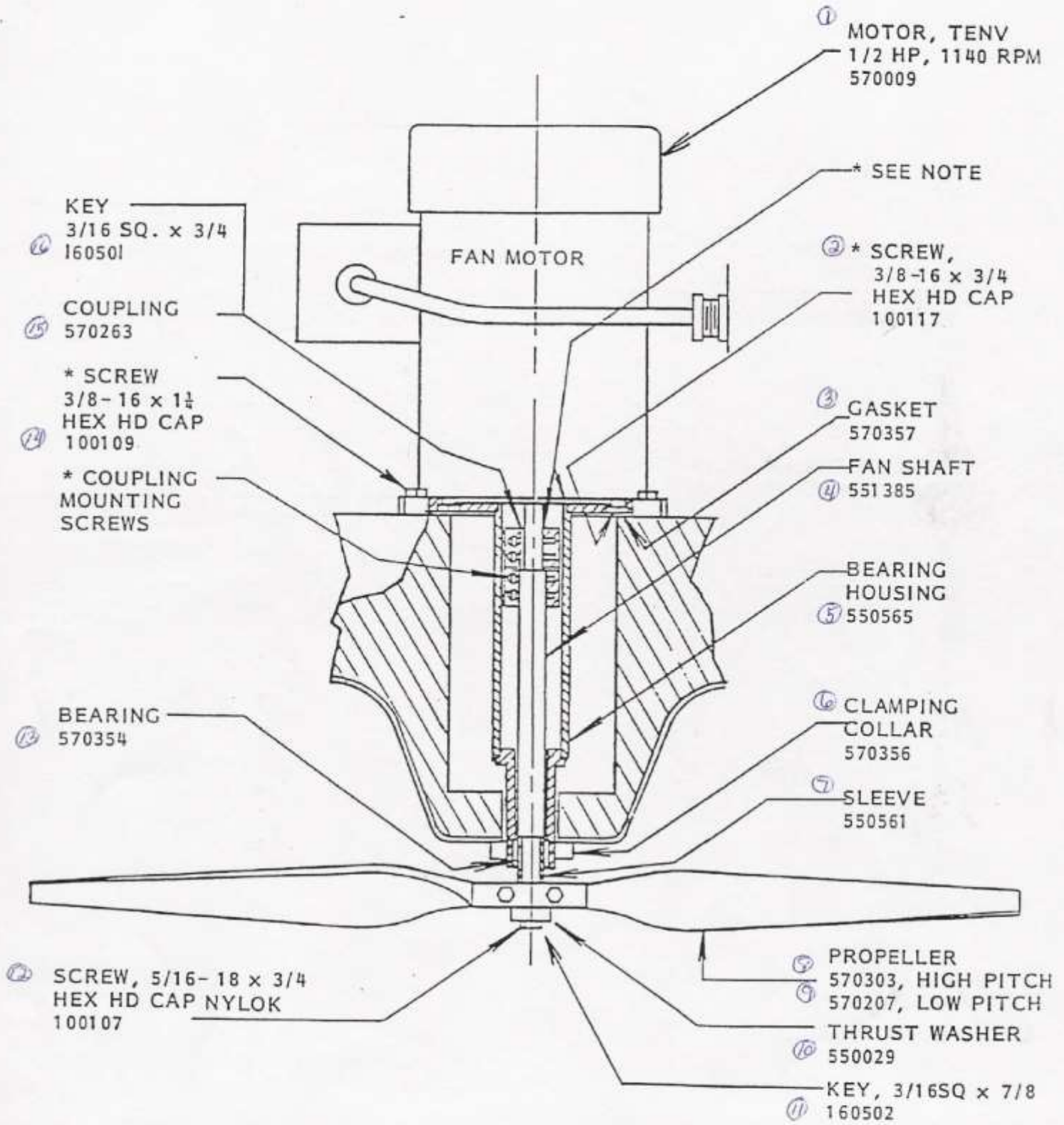

NOTE: \* COAT THIS ITEM WITH SILICONE COMPOUND GE-G661 OR VASELINE AT ASSEMBLY.

VARIABLE SPEED  
 FAN ASSEMBLY  
 (NO BRAKE)  
 C30-550567

# SECTION

# 6

## ULTRA-FREEZE® FIXED SPEED FAN ASSEMBLY

	Part Number	Description	Qty.	Picture of Part
	550568	Fixed Speed Fan Assembly	1	-----
<b>FIXED SPEED FAN ASSEMBLY PARTS SOLD SEPARATELY</b>				
17	160501	3/16 Sq. x 3/4 Key	1	
16	570263	Coupling	1	
15	100109	Screw 3/8-16 x 1/14 Hex Hd	4	-----
14	570354	Bearing	1	
13	100107	Screw, 5/16-18 x 3/4 Hex Hd	1	-----
12	160502	Key, 3/16 Sq. x 7/8	1	
11	550029	Thrust Washer	1	
10	570207	1179 Low Pitch Propeller	1	
9	570303	1171 High Pitch Propeller	1	
8	550561	Sleeve	1	
7	570356	Clamping Collar	1	
6	550565	Bearing Housing	1	
5	551385	Fan Shaft	1	
4	570357	Gasket	1	
2	100117	Screw 3/8-16 x 3/4 Hex Hd	4	-----
1	570212	1 HP Elec. Motor (Painted Blue)	1	

Effective Date: 09/2019

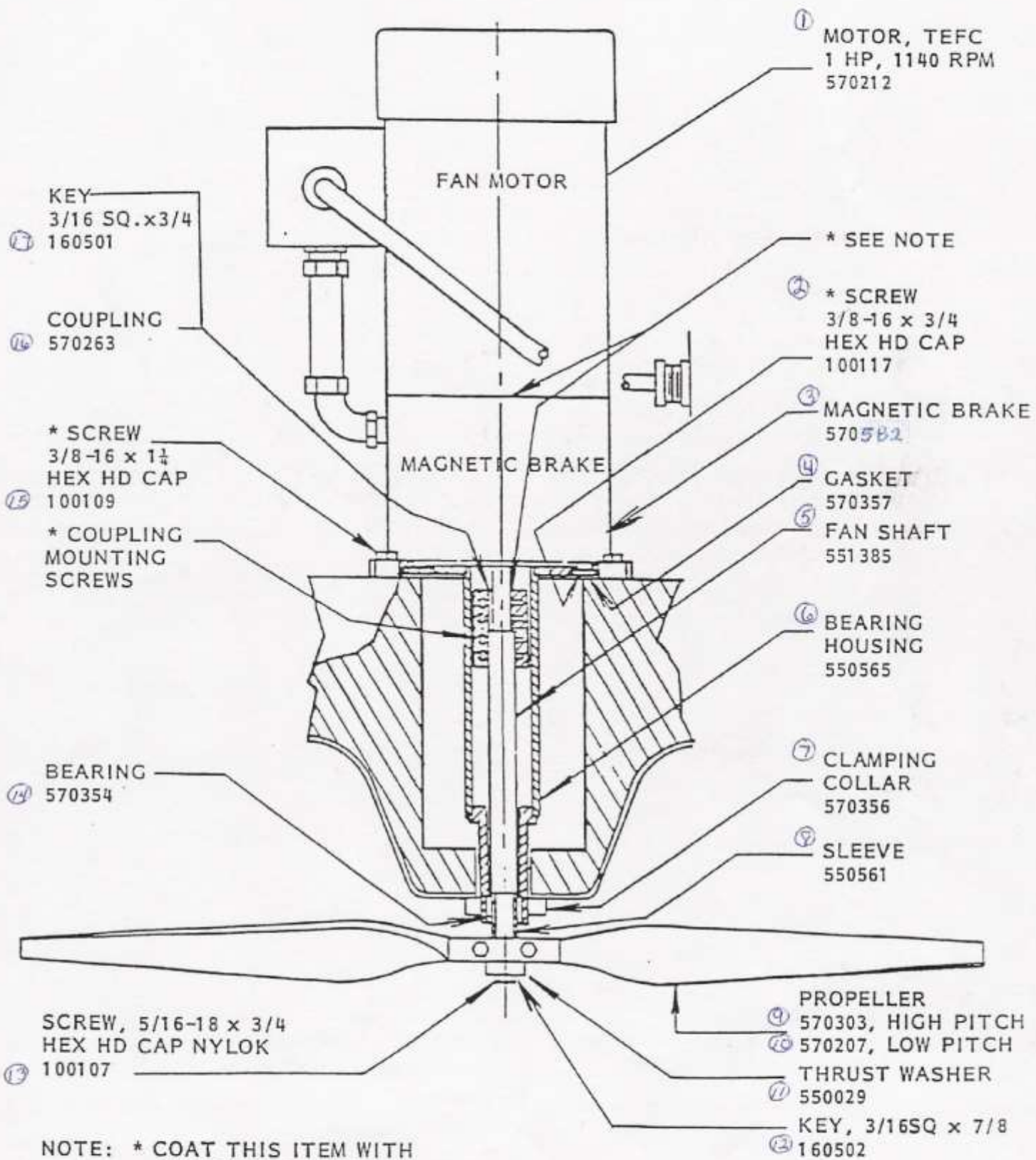

NOTE: \* COAT THIS ITEM WITH SILICONE COMPOUND GE-G661 OR VASELINE AT ASSEMBLY.



FIXED SPEED  
FAN ASSEMBLY  
(with brake)  
D30-550568

# SECTION

# 7

## ULTRA-FREEZE® MODULE RELATED PARTS

	Part Number	Description	Qty.	Picture of Part
1	550699	Lower Door	1	
2	550698	Upper Door	1	
3	550555	Door Rest	1	
4	550734	Pedestal 30" Fiberglass	1	
	550585	Pedestal 48" Aluminum	1	
	551525	Pedestal 30" SST (optional)	1	
	551528	Pedestal 48" SST (optional)	1	
5	550024	Adjustable Leg	1	
6	550976	SST hub for fiberglass & alum. Pedestals	1	
7	135124	Bumper-Shock Absorber	1	
8	550032	Upper Plunger & Hinge Assembly	1	
9	550056	Lower Plunger & Hinge Assembly	1	
10	570053	Gearbox Lower Tier 60:1 (Painted Blue)	1	
11	550404	Apparatus Box	1	
12	550405	Apparatus Box Cover	1	
13	570009	Variable Speed 1/2 HP Fan Motor (Painted Blue) A.C.	1	
14	570377	Gearbox Top Tier 50:1 (Painted Blue)	1	
15	570004	1 HP Drive Motor (Blue) D.C.	1	
	920100-1	1 HP Drive Motor Stainless A.C	1	
16	570257	Warning Label (Fan) English / Spanish	1	
17	570256	Warning Label (Fan) English / French	1	
18	570236	Gasket - Apparatus Box	1	

19	570532	Limit Switch	1	
20	570530	Lever Roller Switch	1	
21	570224	Rivnut Tool	1	
22	110302	1/4-20 SST Rivnut (Hinge Assy)	1	
23	110301	10-32 SST Rivnut (Apparatus Box)	1	
24	570223	10-32 Rivnut Tool	1	
25	570225	3/8-16 Rivnut Tool	1	
26	110305	3/8-16 SST Rivnut (Conveyor Frames/Vestibule)	1	-----
27	550665	Door Retainer	1	
28	570581	Spliced Rod 50"	1	
29	570563	Spliced Rod 32"	1	

Effective Date: 09/2019



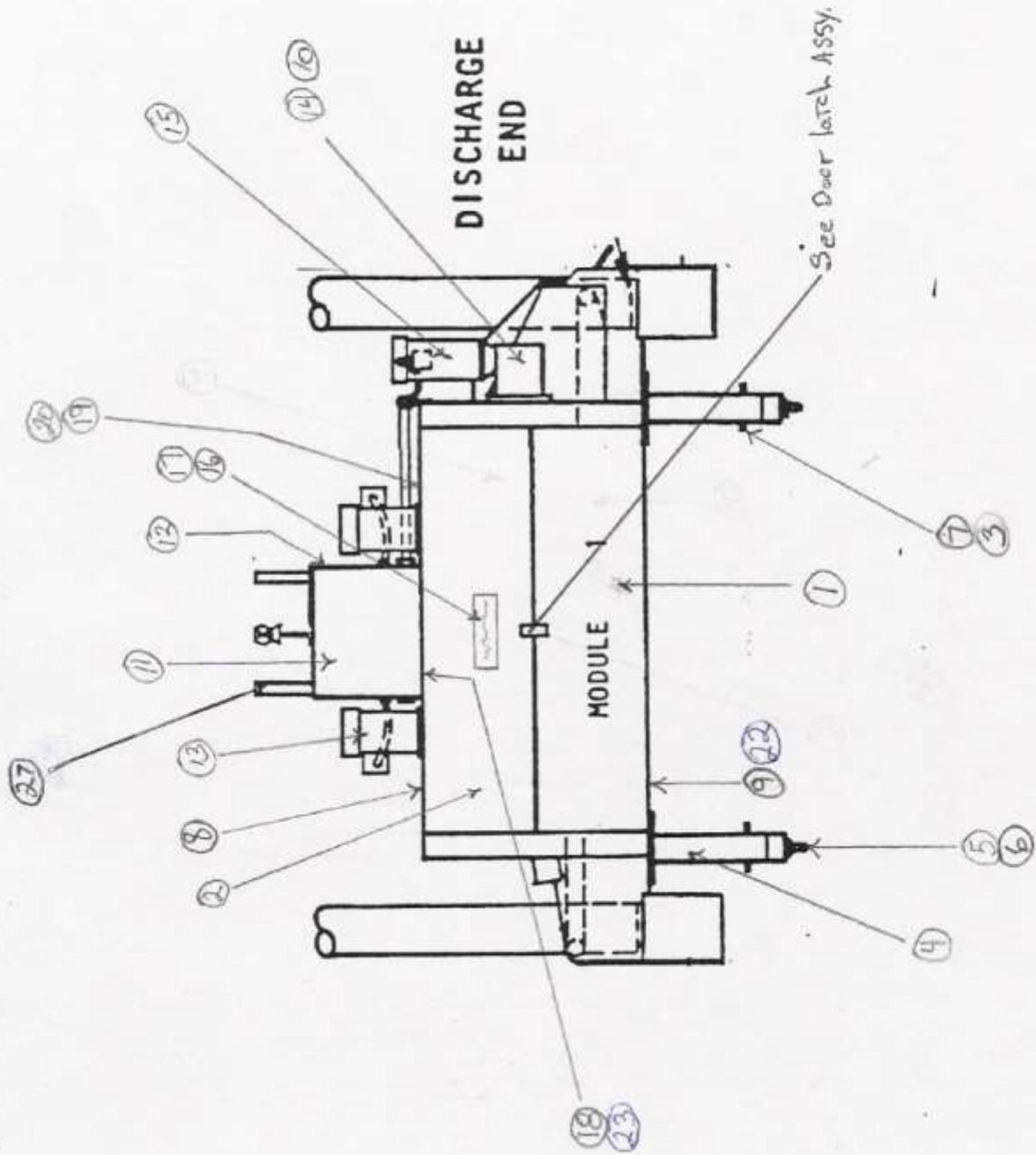

# SECTION

# 8

## ULTRA-FREEZE® CO2 MANIFOLD INJECTION ASSEMBLY

	Part Number	Description	Qty.	Picture of Part
	551159	CO2 Manifold Injection Assembly	1	-----
<b>CO2 MANIFOLD INJECTION SOLD SEPARATELY</b>				
37	170131	Half Union Conn., Flare, MPT	1	
36	170107	Nut, Flare (Short)	1	
35	170274	Valve, 1/4" Ball FPT Ends	1	
34	170231	Nipple, Sch. 40 S.S.	1	
31	550091	Manifold Insert	1	-----
30	120103	#10 Flat Washer S.S.	8	-----
29	110121	#10 - 32 Hex. Locknut	8	-----
28	100201	#10 -32 Machine Screws S.S.	8	-----
27	550108	Coupling, 1/2" Manifold	1	
26	550105	Gasket, Manifold Coupling	2	
25	550109	Coupling, 1/4" Manifold	1	
24	570462	Coil, Solenoid	3	
23	170126	Nipple, Long MPT	1	
22	550104	Gasket	1	
21	550873	Spacer	1	
17	170211	Elbow, FPT	1	
16	170124	Tee, Male, FPT Run & Branch	1	
15	170123	Nipple, MPT	1	

14	170203	Bushing, Reducing Hex. Hd	3	
13	170223	Cross, FPT	1	
12	570480	Gauge, Pressure	2	
11	170129	Elbow, Male MPT	1	
10	170117	Tee, SAE - MPT Branch End	1	-----
9	170201	Bushing, Reducing Hex. Hd	1	
8	170267	Valve, Check	1	
7	170112	Tee, FPT	1	
6	170128	Elbow, Male MPT - SAE	3	
5	570461	Valve, Solenoid	3	
4	170268	Needle Valve	1	
3	170110	Nipple, Close NPT	1	
2	110123	Nut, Hex S.S.	1	-----
Above prices of N/A indicate that the part is not sold separately. This part is only available with the assembly.				

Effective Date: 09/2019

VIEW 4-A

NOTE: SHIP THIS PORTION SEPARATELY TO PREVENT DAMAGE

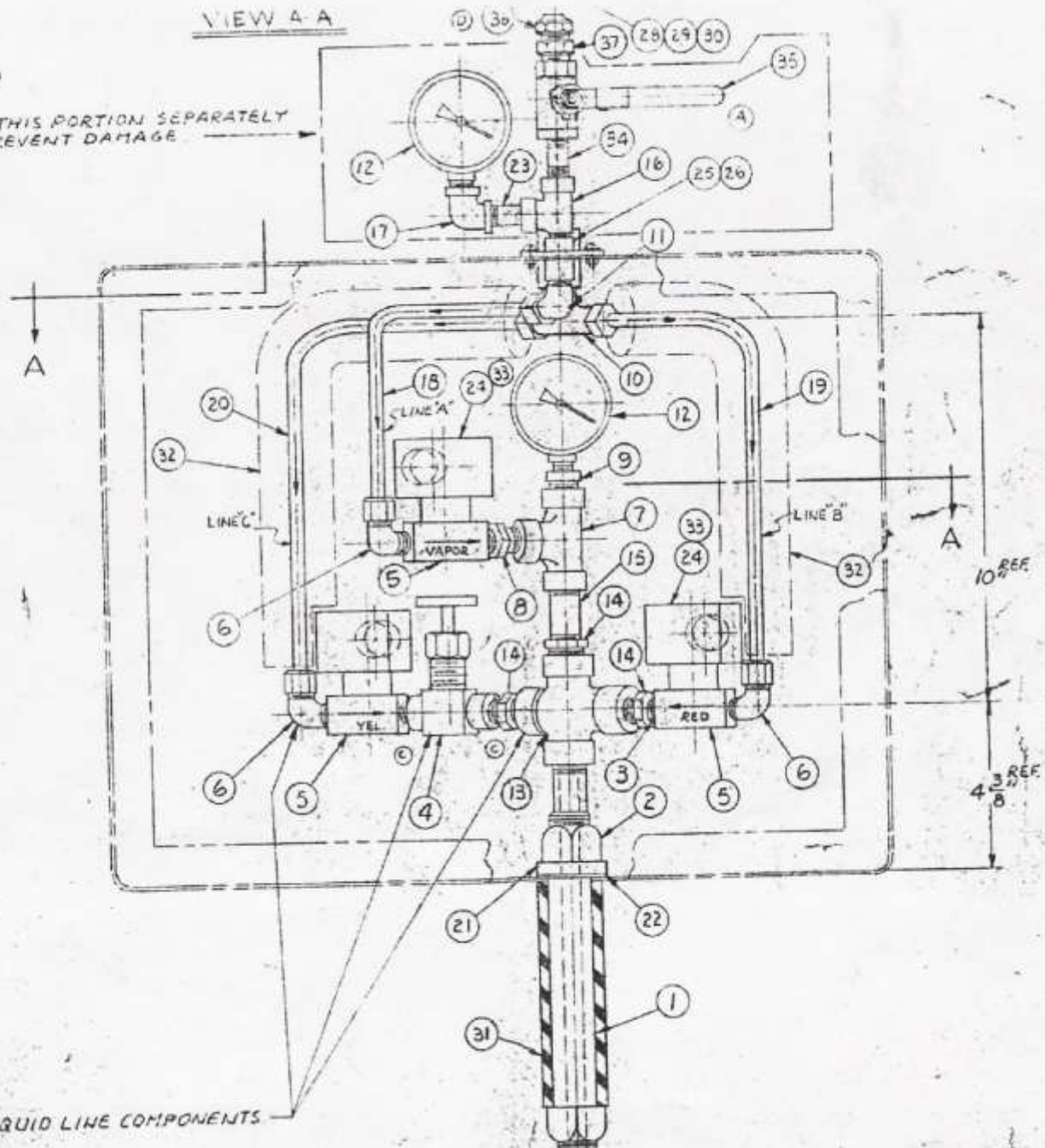











NOTE: INSULATE ALL LIQUID LINE COMPONENTS AND FITTINGS.

# SECTION

# 9

## ULTRA-FREEZE® LN2 MANIFOLD INJECTION ASSEMBLY

	Part Number	Description	Qty.	Picture of Part
	551188	LN2 Manifold Injection Assembly	1	-----
<b>LN2 MANIFOLD INJECTION SOLD SEPARATELY</b>				
43	170353	Vee Jet Nozzle (.062) H 1/8 VV	1	
42	170354	Vee Jet Nozzle (.057) H 1/8 VV	1	
41	170352	Vee Jet Nozzle (.052) H 1/8 VV	1	
40	170351	Vee Jet Nozzle (.043) H 1/8 VV	1	
39	170350	Vee Jet Nozzle (.040) H 1/8 VV	1	
38	170265	Ln2 1" Extended Ball Valve (Not included in assembly)	1	
37	140108	Black Vinyl Plastic Electrical Tape	1 roll	-----
35	140218	Armaflex 11 Insulation 1 5/8 I.D. x 3/4 Wall	1	-----
34	140219	Armaflex 11 Insulation 1 1/8 I.D. x 3/4 Wall	1	-----
33	120103	Washer, Flat #10 S.S.	4	-----
32	110121	Locknut Hex. #10 -32 S.S.	4	-----
31	100201	Screw, Mach. RD. HD. #10 - 32 x 3/4 LG. S.S.	4	-----
30	570520	Gasket, For LN2 CPLG. Mounting Plate	1	
29	550874	Coupling, LN2 Manifold	1	
28	170156	Tube, Copper 7/8 O.D. x 2 3/8 LG. Type "K" .065 Wall	1	-----
27	170156	Tube, Copper 7/8 O.D. x 7 LG. Type "K" .065 Wall	1	-----
26	170183	Elbow, 45°. Solder	1	
25	170205	Bushing, Reducing	1	

24	170171	Connector, Male Tube	2	
23	170188	Tee, Male Branch Tube	1	
22	551140	Manifold, Insert LN2	1	
21	130119	Bushing, Insulating 1/2 Adalet	2	
20	170153	Tube, Copper 5/8 O.D. x 1 3/4 LG. Type "K"	4	-----
19	170153	Tube, Copper 5/8 O.D. x 2 1/2 LG. Type "K"	1	-----
18	551129	Manifold, Intermediate LN2	1	
17	551187	Pigtail Assembly For Pressure Gauge	1	-----
16	551143	Gasket	2	
14	551147	Spacer, 3/8 Thick	1	
13	170214	Nipple, Hex. 3/4 Pipe	1	
12	110125	Nut, Jam NF Hex. (S.S.)	1	
11	170290	Gauge, 100 PSI 2" Dia. Face	1	
10	170135	Connector, Female	1	
9	170103	Connector, Male	1	
8	570010	Valve, Magnatrol 1/2	2	
7	170278	Valve, Ball 1/2 Pipe	1	
6	170225	Nipple, Hex. 1/2 Pipe	1	
5	170298	Adapter, 5/8 O.D. Solder to 1/2 MPT	2	-----
4	170297	Elbow, 90° FPT	1	-----
3	170296	Elbow, 90° MPT	3	-----
2	551136-2	Tee, Modified LN2 (W/O Port)	1	
1	551136-1	Tee, Modified LN2 (With Port)	1	
Above prices of N/A indicate that the part is not sold separately. This part is only available with the assembly.				

Effective Date: 09/2019



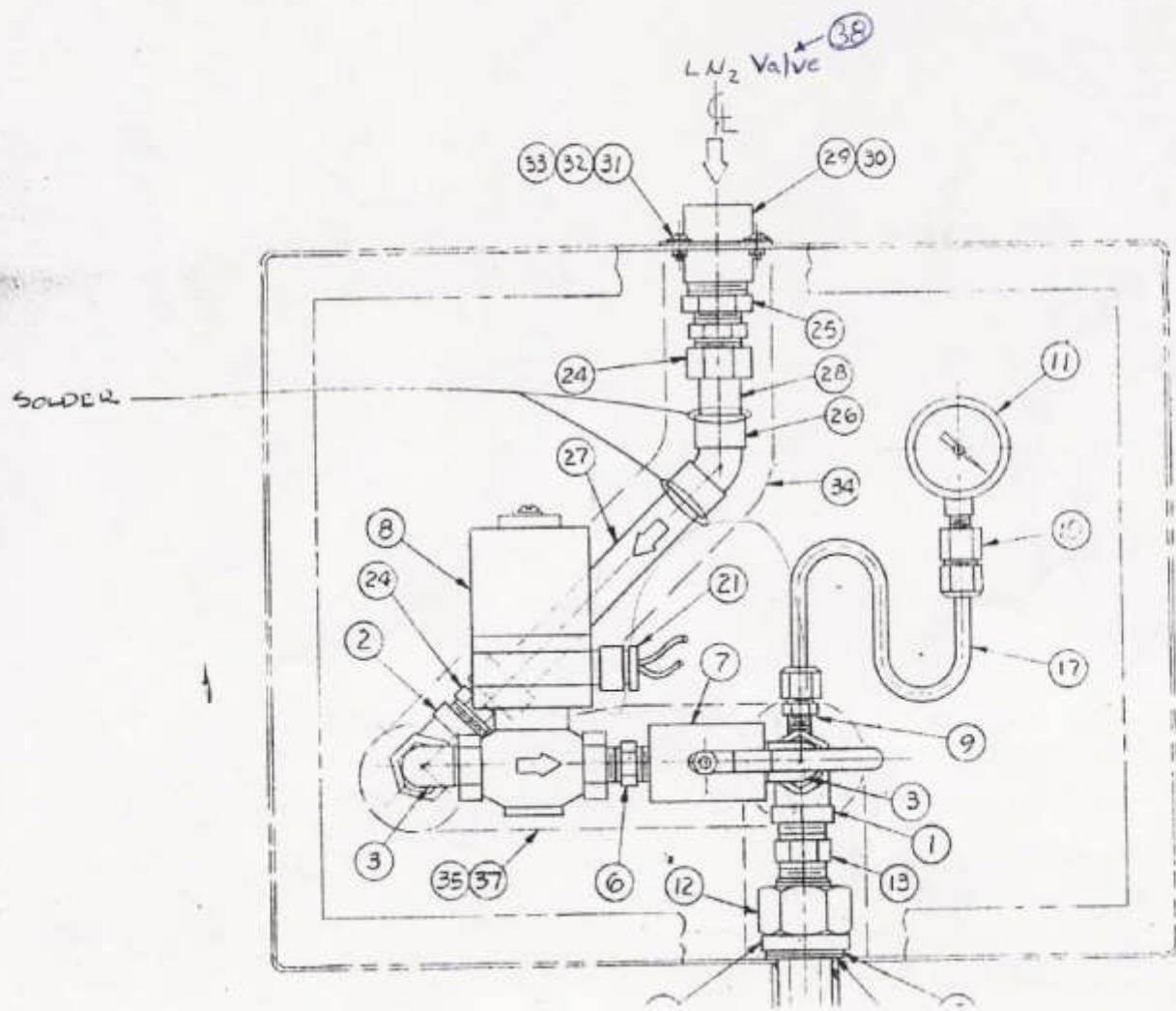
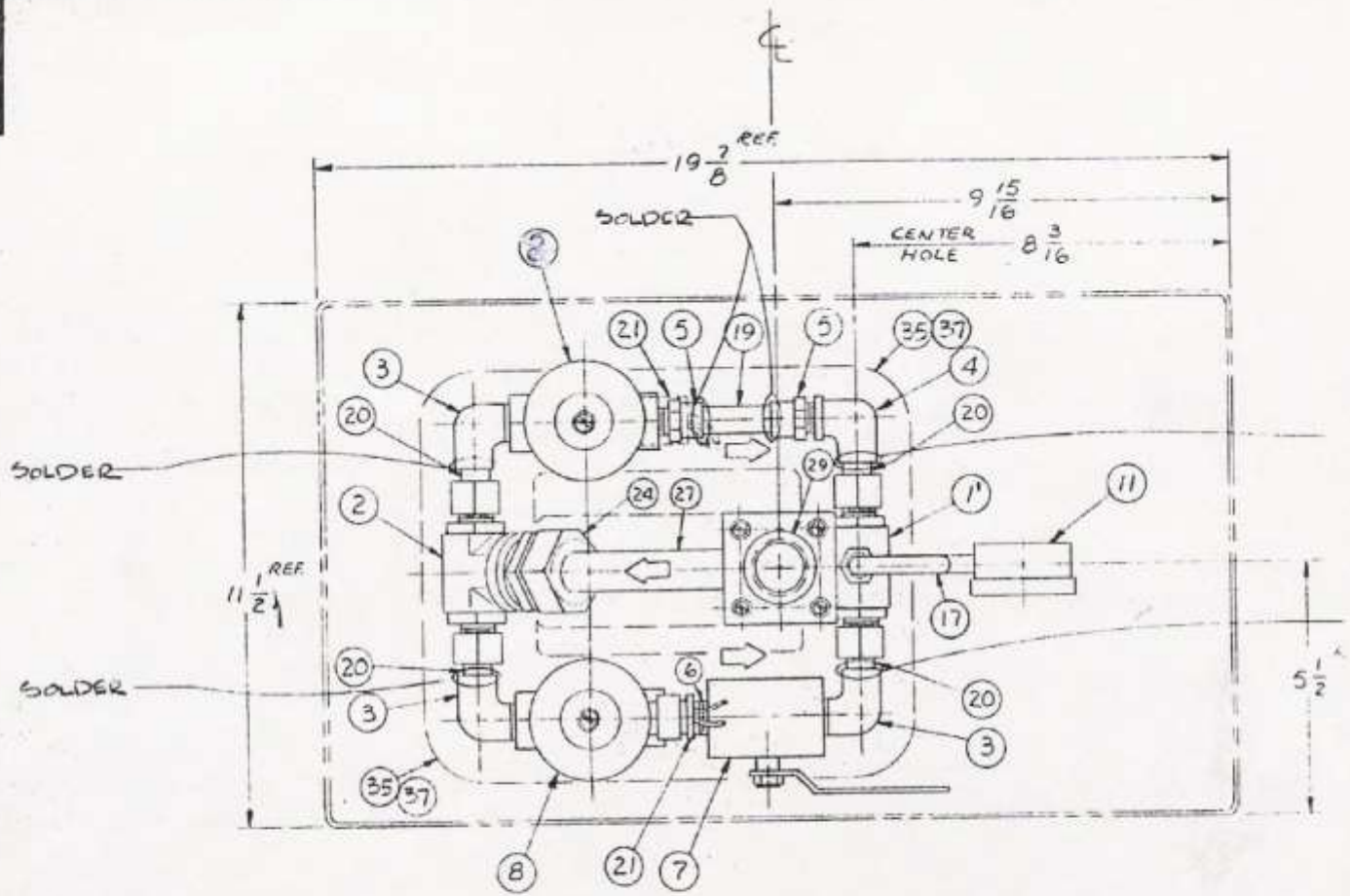

# SECTION

# 10

## ULTRA-FREEZE® DOOR LATCH ASSEMBLY

	Part Number	Description	Qty.	Picture of Part
	550087	Door Latch Assembly	1	-----
<b>LATCH PARTS SOLD SEPARATELY</b>				
14	550082	Striker Plate (Lower Door)	1	
13	120103	1/4" Lock Washer Spg.	1	-----
11	550086	Short Hinge Leaf	1	
10	550214	Pin	2	
9	570085	Knob	1	
8	110102	1/4" 20 Hex Nut SST	1	-----
7	550085	Long Hinge Leaf	1	
6	550084	Intermediate Hinge Leaf	1	
4	550215	Roller Pin	1	
2	550081	Adjusting Rod	1	
1	550080	Adjusting Bar	1	

Effective Date: 09/2019

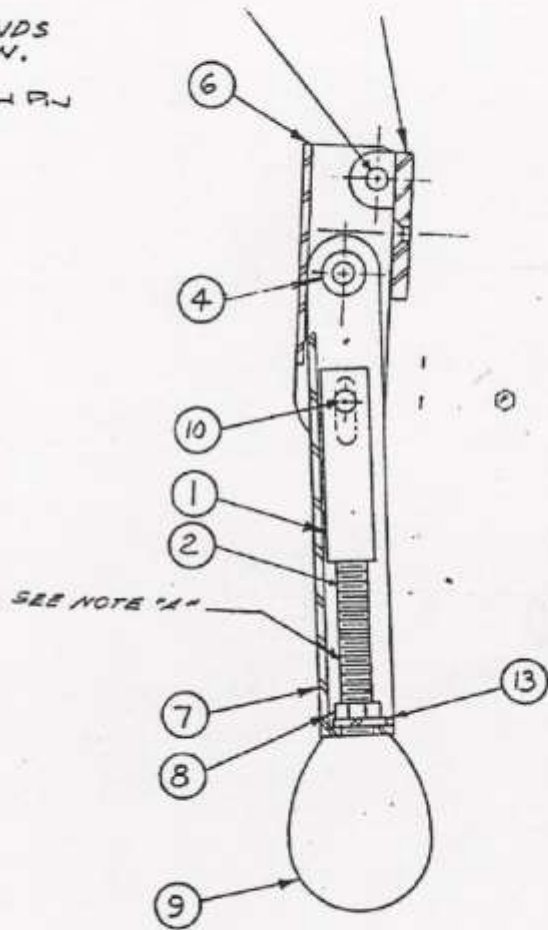
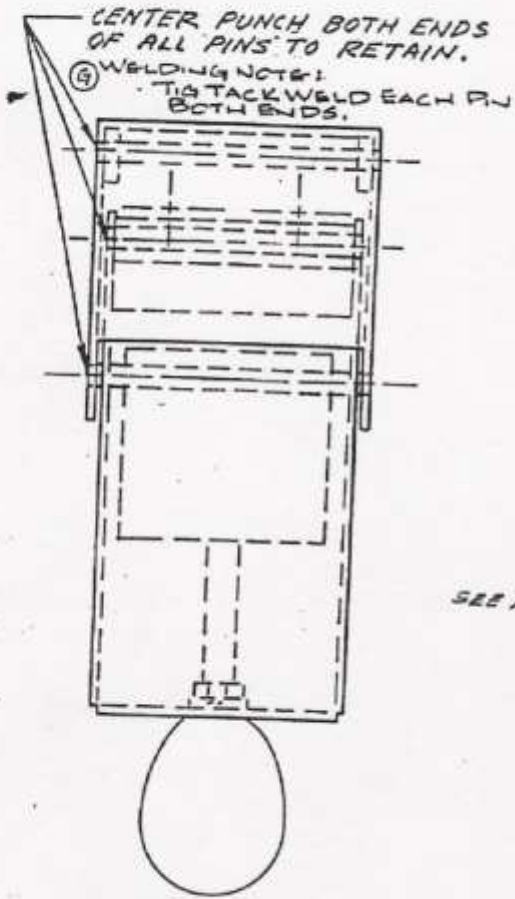

**NOTE - "A"**

AFTER ASSEMBLY GRIP ADJUSTING ROD (ITEM #2) WITH VISEGRIP PLIERS ABOVE LOCKNUT (ITEM #8) WITH NUT LOOSE SCREW KNOB (ITEM #9) AS TIGHT AS POSSIBLE TO ADJUSTING ROD.





- 100301 Ⓞ Flat Head SST Phillips
- 550003 Ⓞ Shim Plate
- 550082 Striker Plate (Bottom Door)

LESS OTHERWISE SPECIFIED DIMENSIONS ARE IN INCHES TOLERANCES ON DIMENSIONS DECIMALS ANGLES ± ±	DRAFTSMAN W. R. JOHNSON	DATE 2-23-73	NAME	CHEMETRON CORPORATION CARDOX PRODUCTS DIVISION <b>CARDOX</b> EQUIPMENT ENGINEERING
	CHECKER		DOOR LATCH ASSEMBLY ULTRA FREEZE UNIT	
TITLE BILL OF MATERIAL	ENGINEER MADHU	DATE 11-2-72		DWG. NO.
APPROVAL			STOCK NUMBER 30-350087	C30-550087
			SCALE 1/4" = 1" WT.	

# SECTION

# 11

## ULTRA-FREEZE® LOWER DOOR PLUNGER AND HINGE ASSEMBLY

	Part Number	Description	Qty.	Picture of Part
	550057	Lower Door Plunger and Hinge Assembly	1	-----
<b>PLUNGER AND HINGE ASSEMBLY PARTS SOLD SEPARATELY</b>				
10	570018	Spring for lower plunger - 550056 -For rebuilding plunger	1	
9	110104	Acorn Nut	4	-----
7	550013	Hinge Pin	2	
6	550006	Hinge Pin Bearing	2	
5	135101	Hitch Pin Clip	2	
4	550014	Plunger Pivot Pin	1	
3	550054	Door Bracket	1	
2	550055	Plunger Bracket	1	
1	550056	Plunger Assembly	1	

Effective Date: 09/2019

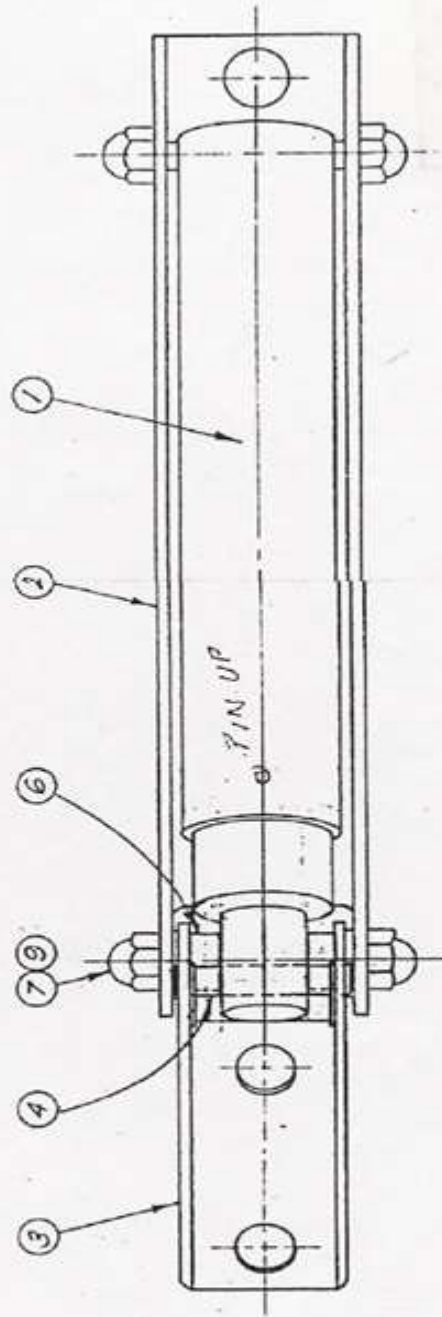
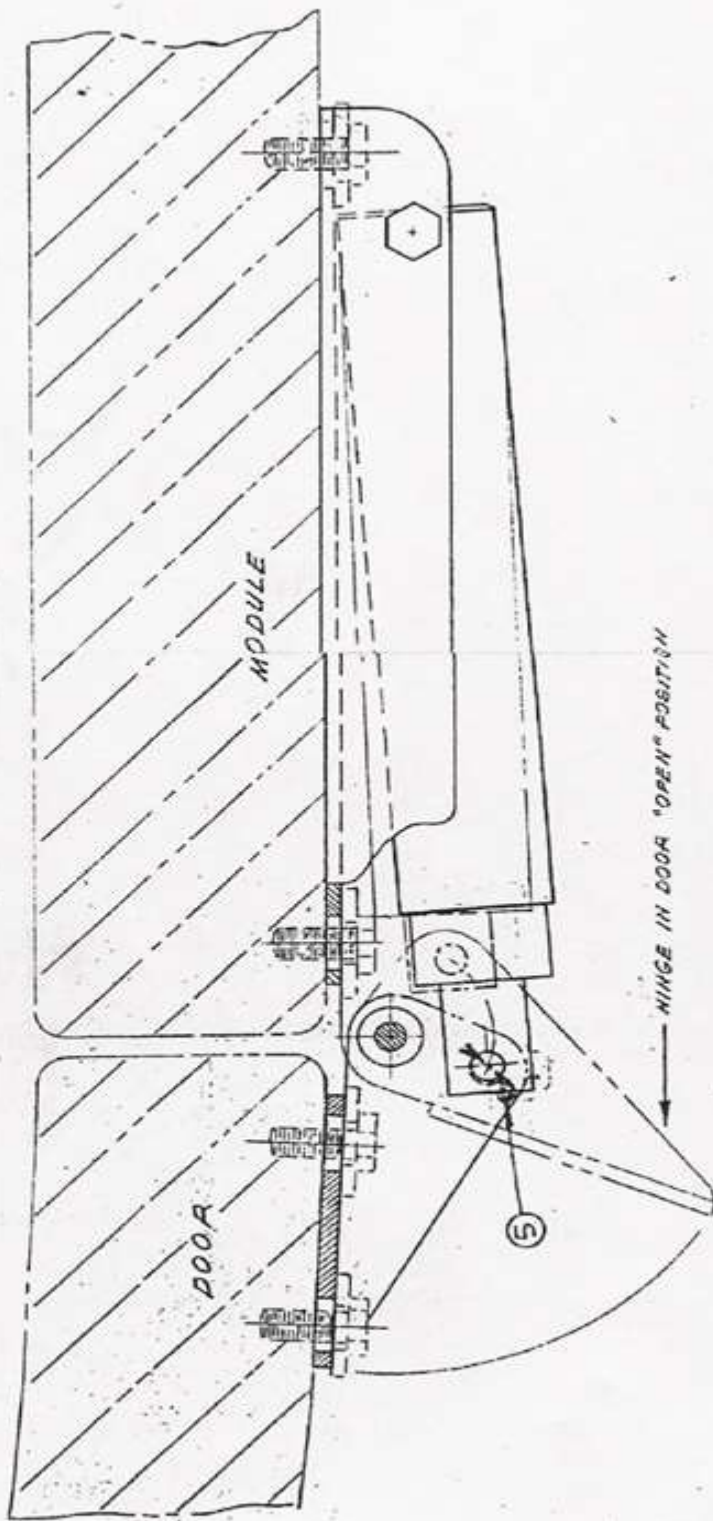







Lower door  
Plunger & Hinge

# **SECTION**

# **12**



## ULTRA-FREEZE® UPPER DOOR PLUNGER AND HINGE ASSEMBLY

	Part Number	Description	Qty.	Picture of Part
	550050	Upper Door Plunger and Hinge Assembly	1	-----
<b>PLUNGER AND HINGE ASSEMBLY PARTS SOLD SEPARATELY</b>				
11	570526	Spring for upper plunger - 550032 - For rebuilding plunger - To be used with 570527	1	
10	570527	Spring for upper plunger 550032 - For rebuilding plunger - To be used with 570526	1	
9	110104	Acorn Nut	4	-----
7	550013	Hinge Pin	2	
6	550006	Hinge Pin Bearing	2	
5	135101	Hitch Pin Clip	2	
4	550014	Plunger Pivot Pin	1	
3	550034	Door Bracket	1	
2	550035	Plunger Bracket	1	
1	550032	Plunger Assembly	1	

Effective Date: 09/2019

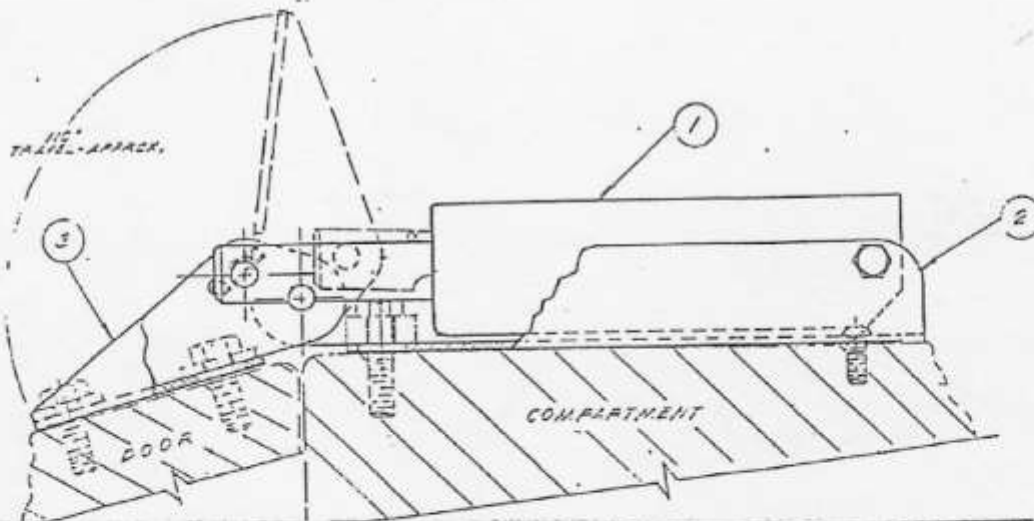
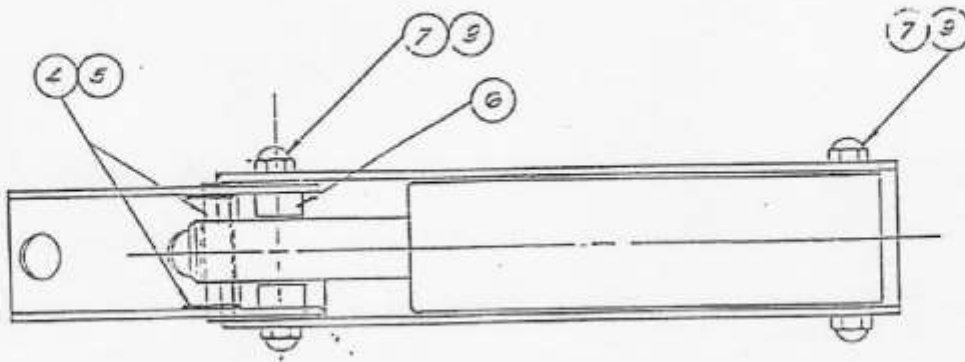

DRAFTSMAN W. R. JOHNSON	DATE 1/16/73	NAME <b>UPPER DOOR HINGE ASSEMBLY ULTRA FREEZE UNIT</b>	CHEMETRON CORPORATION CARDOX PRODUCTS DIVISION <b>CARDOX®</b> <small>CHEMETRON</small> EQUIPMENT ENGINEERING
CHECKER		DWG. NO. <b>C30-550050</b>	
ENGINEER		STOCK NUMBER <b>30-550050</b>	
ENGINEER		SCALE <b>FULL</b> WT. _____	
APPROVAL <i>RCE</i>	1-17-73		

# **SECTION**

# **13**

## ULTRA-FREEZE® CONTROL CABINET ITEMS Variable Speed

	Part Number	Description	Qty.	Picture of Part
1	570261	Starters (Blower)	2	
2	570261	Starters (Fan)	1	
3	570287	8 Pin Octal Socket	1	
	570331	Relay, DPDT	1	
4	570587	Inverter	1	
5	570027	Disconnect Switch	1	
6	570589	DC Motor Controller 1HP	1	
7	570029	Transformer	1	
8	570115	Ultra-Freeze® Decal	1	
9	570597	Temperature Controller	1	
10	570023	Conveyor Speed Indicator	1	
11	570588	Potentiometer Conveyor Spd	1	
12	920197	Enclosure	1	
14	570070	Single Button Operator (for instrument power, exhaust blower, conveyor drive)	1	
15	570067	Start Button	1	

16	570068	Green Lens	1	
17	570347	120 PSB Lamp	1	
18	570325	Lens (red power on)	1	
19	570593	Potentiometer (fan motors)	1	
20	570550	Operator (fan motors)	1	
21	570551	Start Button for 570550	1	
22	570552	Lens (green) for 570550	1	
23	570553	Reset Button for 570550	1	
23	570004	Single contact block for 570550	2	-----
24	570382	Dual Indicating Light (for inverter)	1	
25	570381	Red Lens (ON)	1	
26	570380	Amber Lens	1	
27	7-936-0069	Label - Disconnect Power	1	
28	570032	Door Hardware Kit (small console)	1	
29	570360	RTD Probe	1	
<b>Please call for parts not listed – 815-468-6115</b>				

Effective Date: 09/2019

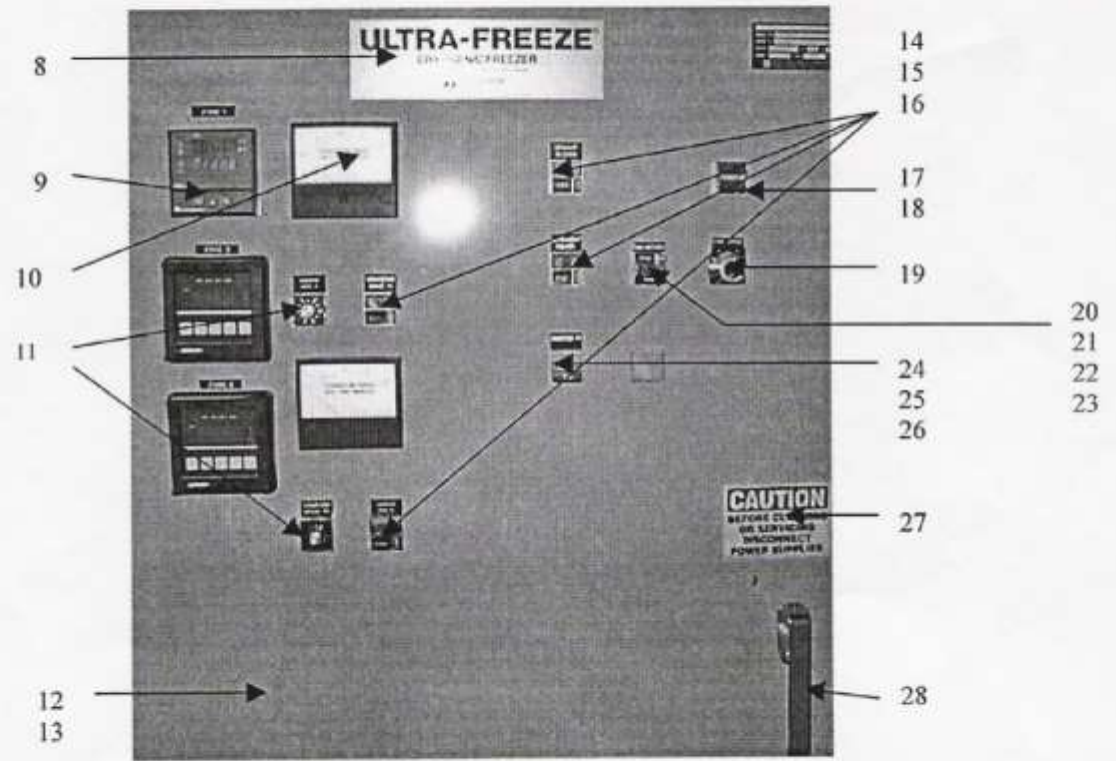
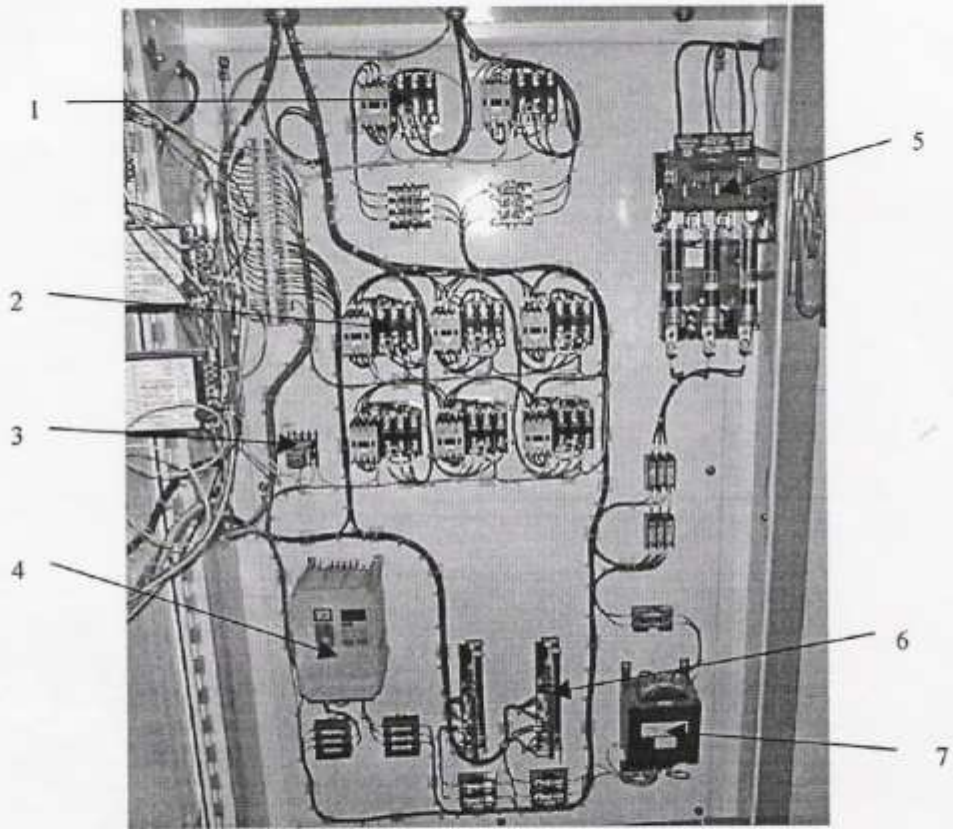

# SECTION

# 14

**ULTRA-FREEZE®**  
**LIMIT SWITCH ITEMS**  
**(DOOR SAFETY SWITCH - FAN BLADES STOP WHEN DOOR OPENS)**

For Relocating Existing GE Model				
	Part Number	Description	Qty.	Picture of Part
1	551270	Switch Mounting Plate	1	
2	570530	Switch Roller Lever	1	
3	130106	Cable Connector – ½”	2	
4	130104	O-Ring & Steel Gasket – ½”	1	
5	130103	Bonding Lock Nut	1	
6	150109	Electric Cable - 4 Cond.	1	-----
7	100144	Hex Head Scr. - #10-32 x ¼”	2	-----
8	120309	Lock washer ext. Tooth #10	2	-----
9	135131	Nylon Plug Button – 5/8”	1	-----
10	135130	Nylon Plug Button - 3/16"	2	-----
11	135132	Nylon Plug Button - 3/4"	1	-----
16	100120	¼ -20 NC x 1"LG. Hex Hd. Sc	1	-----
17	100202	#10-32 NC x ½ Rd. Hd. Sc	2	-----
18	551494	Spacer, Upper Door Stop	1	
<b>Please call for parts not listed – 815-468-6115</b>				

Effective Date: 09/2019



**ULTRA-FREEZE®**  
**LIMIT SWITCH ITEMS**  
**(DOOR SAFETY SWITCH - FAN BLADES STOP WHEN DOOR OPENS)**

For New Limit Switch Installation				
	Part Number	Description	Qty.	Picture of Part
1	551270	Switch Mounting Plate	1	
2	570530	Switch Roller Lever	1	
3	570532	Limit Switch, Submersible	1	
4	130106	Cable Connector – ½”	2	
5	130104	O-Ring & Steel Gasket – ½”	1	
6	130103	Bonding Lock Nut ½”	1	
7	100402	Fillstr. Hd. Scr #10 – 32x1 ¾	1	-----
8	100401	Fillstr. Hd. Scr #10 – 32x1 ½	1	-----
9	110127	Kepnut #10 - 32	2	-----
16	100120	¼ -20 NC x 1LG. Hex Hd. Sc.	1	-----
17	100202	#10-32 NC x ½ Rd. HD. Sc.	2	-----
18	551494	Spacer, Upper Door Stop	1	
<b>Please call for parts not listed – 815-468-6115</b>				

Effective Date: 09/2019

SYM.	REVISIONS	DATE	APPR.
A	ITEM #16 WAS 1/8 LG. ADDED ITEM #18	5-23-91	M/D

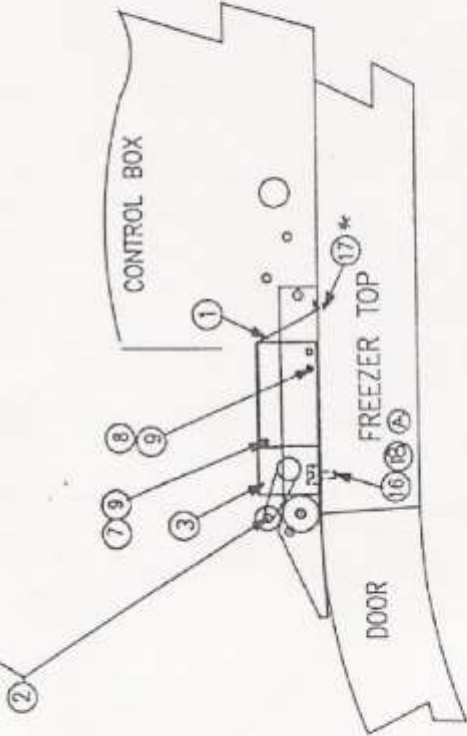
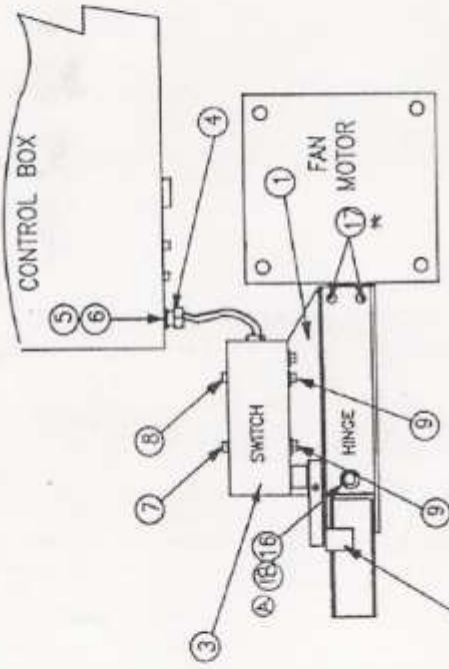

ITEM NO.	DESCRIPTION	STOCK NO.	QUANTITY
1	SWITCH MOUNTING PLATE	30-551270	1
2	SWITCH ROLLER LEVER	30-570530	1
3	LIMIT SWITCH, SUBMERSIBLE	30-570532	1
4	CABLE CONNECTOR - 1/2"	30-130106	1
5	O-RING & STEEL GASKET - 1/2"	30-130104	1
6	BONDING TYPE LOCKWUT - 1/2"	30-130103	1
7	FILLSTR. HD. SCR #10-32X1 3/4	30-100402	1
8	FILLSTR. HD. SCR #10-32X1 1/2	30-100401	1
9	WASHER #10-32	30-110127	2
10	1/4-20 NC X 1 1/4 HEX. NO. SC	30-100126	2
11	1/4-20 NC X 1 1/2 HD. NO. SC	30-100702	2
12	SPACER, UPPER DOOR STOP	30-551444	1

NOTES:





- 1 - TWO KITS REQD. PER MODULE
- 2 - FOR STEP BY STEP INSTALLATION INSTRUCTIONS, REF. TO DWG. B30-550454
- 3 - (V) OPTIONAL - ONLY FOR CORRODED SCREW REPLACEMENT

 CARDORX CORPORATION <small>MEMBER OF LOUISIANA CORPORATION</small> TECHNICAL CENTER COUNTRYSIDE, LA 70525	UNITS	TITLE
	SCALE	FOR NEW LIMIT SWITCH INSTALLATION
DRAWN T.B. APP'D.	DATE	DWG. NO.
	T-11-68	B30-550451

# SECTION

# 15

## ULTRA-FREEZE® LOWER DOOR GASKET AND GASKET HARDWARE



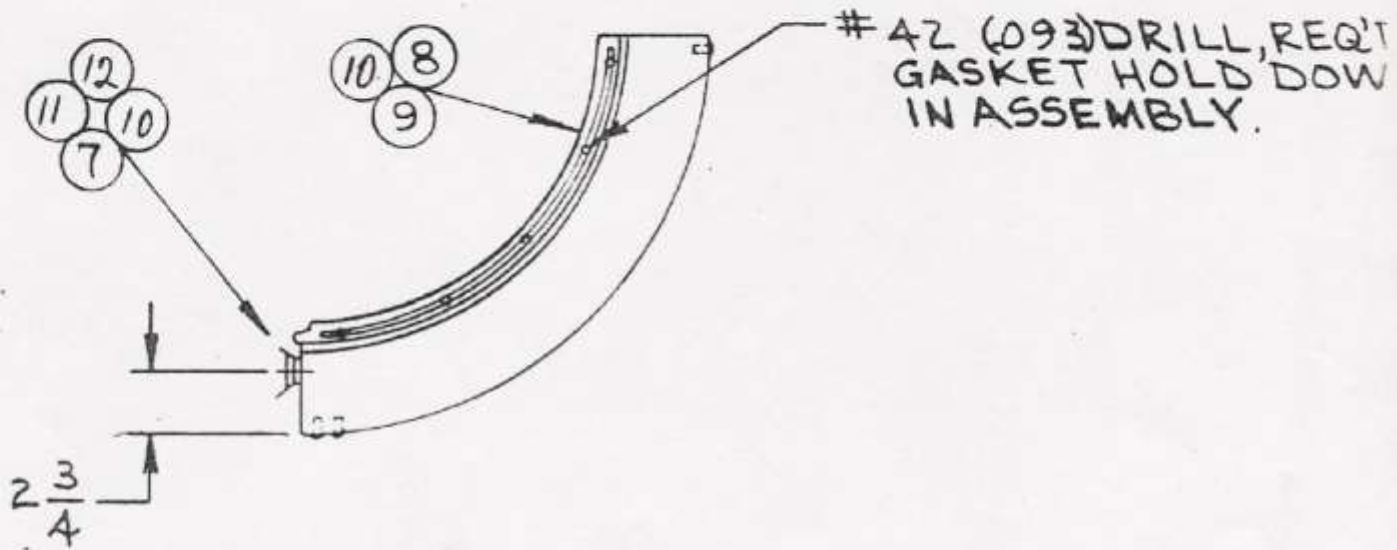

	Part Number	Description	Qty.	Picture of Part
<b>GASKET AND GASKET HARDWARE SOLD SEPARATELY</b>				
12	550489	Gasket Guide- Straight SST	1	
11	550490	Gasket - Straight - Spon Polyester	1	
10	100534	#6 x 5/8" Phillips Fl. Hd	25	-----
9	550491	Curved Gasket - Spon Polyester	2	
8	550572	Curved Hold Down Strip SST	2	
7	550075	Hold Down Strip - Straight SST	1	
6				
5				
4				
3				
2				
1				

Effective Date: 09/2019



GASKET LOCATION-LOWER DOOR

## ULTRA-FREEZE® UPPER DOOR GASKET AND GASKET HARDWARE

	Part Number	Description	Qty.	Picture of Part		
<b>GASKET AND GASKET HARDWARE SOLD SEPARATELY</b>						
12	550489	Gasket Guide- Straight SST	2			
11	550490	Gasket - Straight - Spon Polyester	2			
10	100534	#6 x 5/8" Phillips Fl. Hd	40	-----		
9	550491	Curved Gasket - Spon Polyester	2			
8	550572	Curved Hold Down Strip SST	2			
7	550075	Hold Down Strip - Straight SST	2			
6						
5						
4						
3						
2						
1						

Effective Date: 09/2019

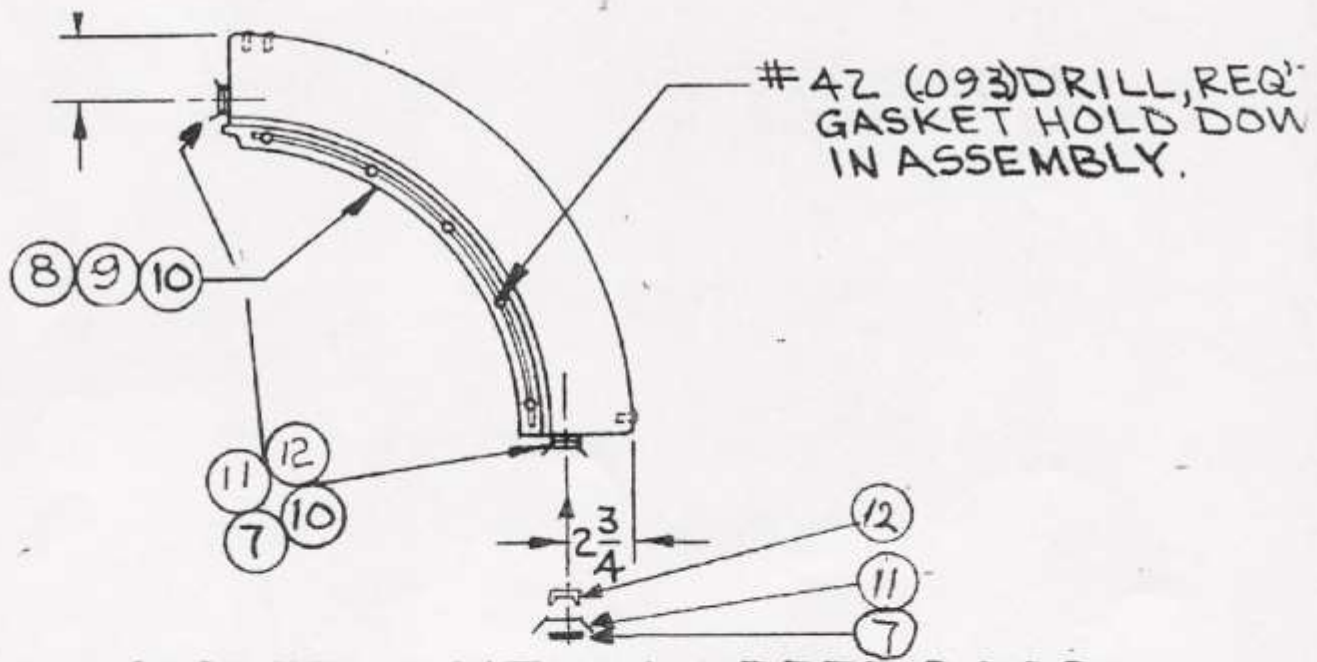

GASKET LOCATION-UPPER DOOR

# SECTION

# 16



## ULTRA-FREEZE® INSTALLATION BELT SUPPORT-ENTRY

	Part Number	Description	Qty.	Picture of Part
1	550625-SRH	Frame Entry R.H. 30"	1	
2	550626	Frame Entry L.H. 30"	1	
3	550677	Take-up Retainer PI Middle Conv.	2	
4	550676	Take-up Slide, Middle Conv.	2	
5	550508	Take-up Shaft 3/4 Dia. x 33 3/4 Lg.	2	
	550648	Take-up Shaft 3/4 Dia. x 52" Lg.	2	
6	550507	Bearing 3/4 Dia. Modified	4	
7	551185	Sprocket-Belt Support	4	
8	550525	Belt Support Plastic	6	
9	551186	Spacer-Bearing/Sprocket	4	

Effective Date: 09/2019

# SECTION

# 17

## ULTRA-FREEZE® CONVEYOR BRUSH ASSEMBLY

Part Number	Description	Qty.	Picture of Part
1	550313 Drive Shaft 30" 550576 Drive Shaft 48"	1 1	
2	550331 Chain Tightener Arm	1	
3	550368 30" UF Key 1/4 sq. x 31/32" 48" UF Key 1/4 sq. x 31/32"	2 2	
4	550694 UF 30" Brush Shaft 550724 UF 48" Brush Shaft	1 1	
5	550709 Clevis – Take Up	2	
6	550710 Bearing – Take Up Clevis	2	
7	550711 Spacer, Thick	1	
8	550721 Chain Guard	1	
9	570310 Sprocket 20T 1" Bore	1	
10	570312 Idler Sprocket	1	
11	570314 Roller Chain #40 24" lg	1	
12	570316 Connecting Link	1	
13	570463 30" Spiral Brush 570464 48" Spiral Brush	1 1	
14	570387 Sprocket 13T 1" Bore	1	
15	550363 Spacer, Thin	1	

Effective Date: 09/2019